

AQHA *eBooks*

Showmanship Patterns

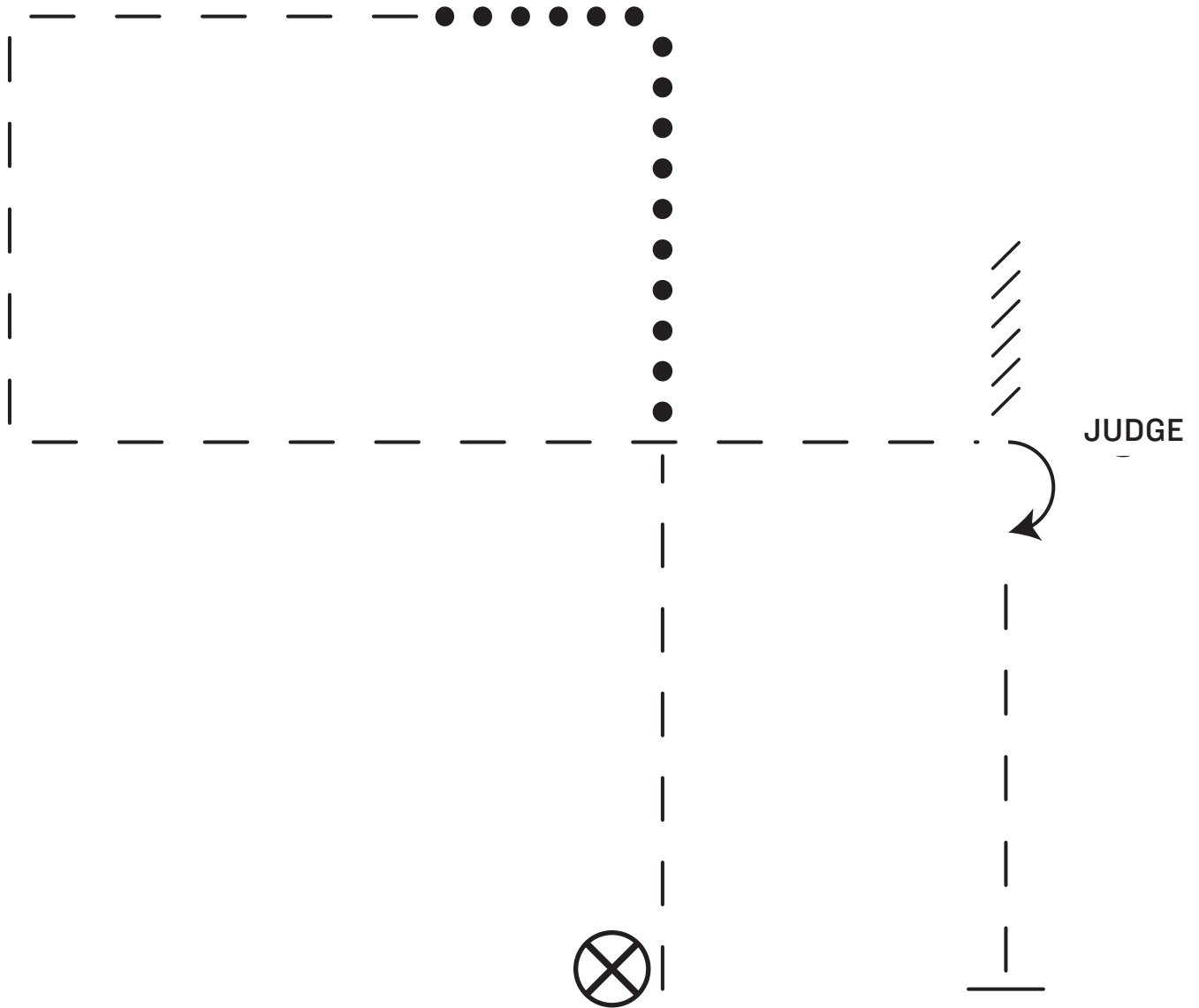



1. Trot until even with judge
2. Walk for 3 horse lengths and walk a corner
3. Trot 3 horse lengths and trot a corner, continue trotting and trot corner to judge
4. Stop and set up for inspection
5. When excused, do a 90° turn
6. Back 1 horse length
7. Exit at a walk or trot

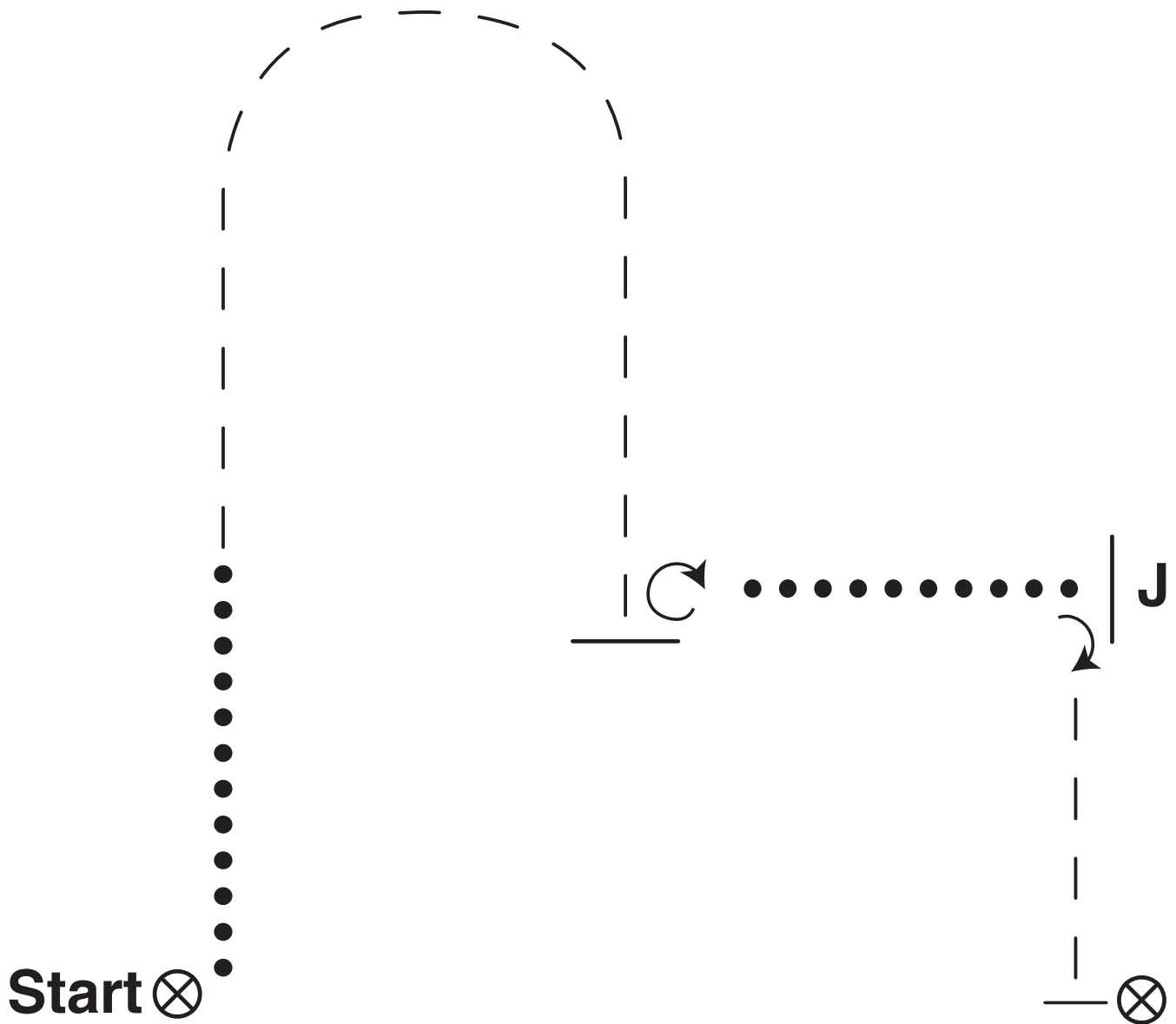

1. Walk 1/2 line
2. Trot around end and down line
3. Halt and execute a 1/3 turn
4. Walk to judge
5. Set up for inspection
6. After inspection, 1/4 turn and trot to marker, stop
7. Exit at a walk or trot

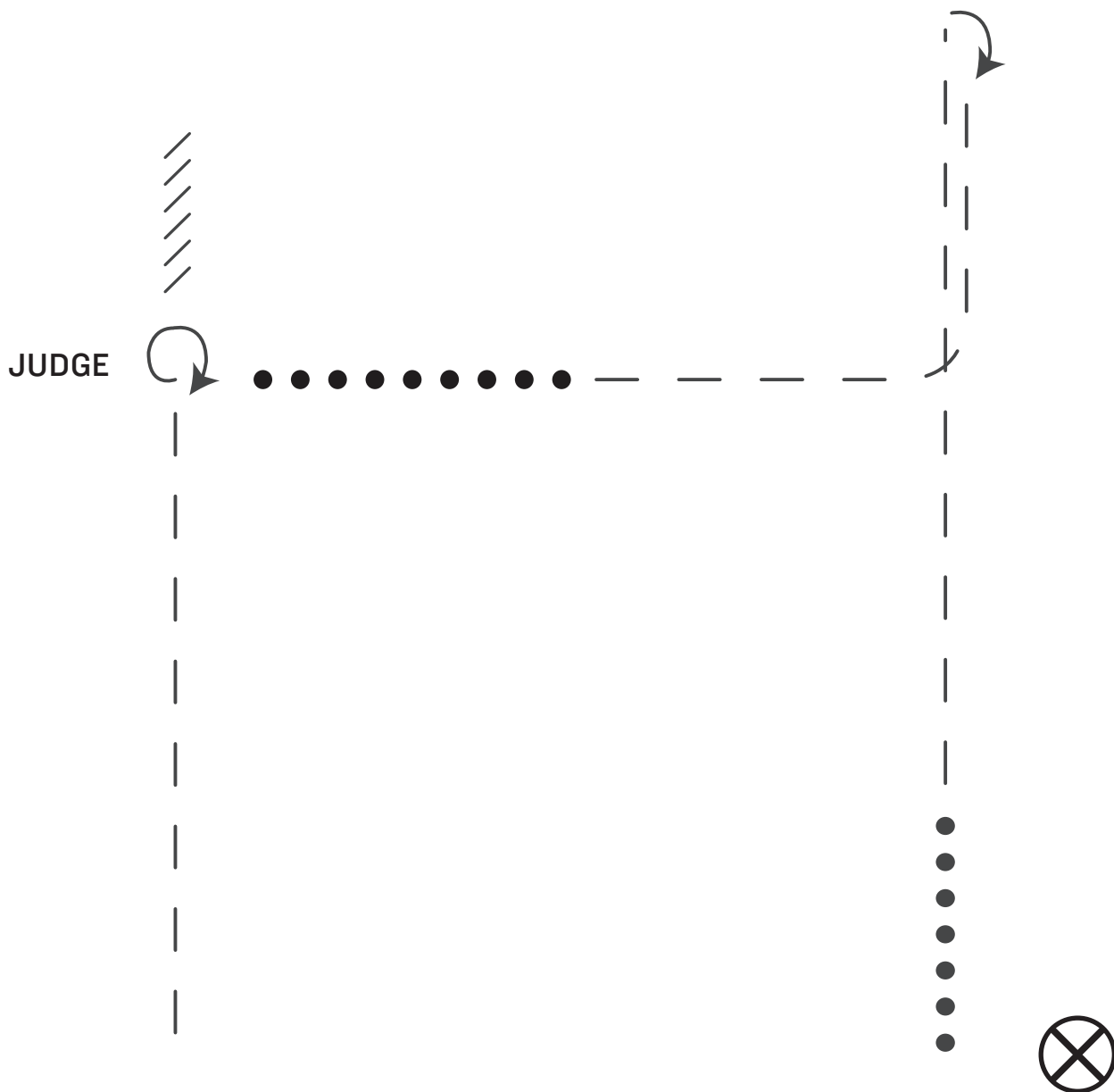

1. Be ready at cone. Walk 1/3 of the distance of your line.
2. Trot to the end of your line
3. Stop and execute 1/2 turns
4. Trot down line and turn toward the judge. After making the corner, trot 1/2 way to the judge
5. Walk to the judge and set up
6. Inspection
7. After inspection, execute a 3/4 turn
8. Back approximately 2 horse lengths and exit at the trot

Note: The drawn description of this pattern is only intended for the general depiction of the pattern. Contestants should utilize the arena space to best exhibit their horses.

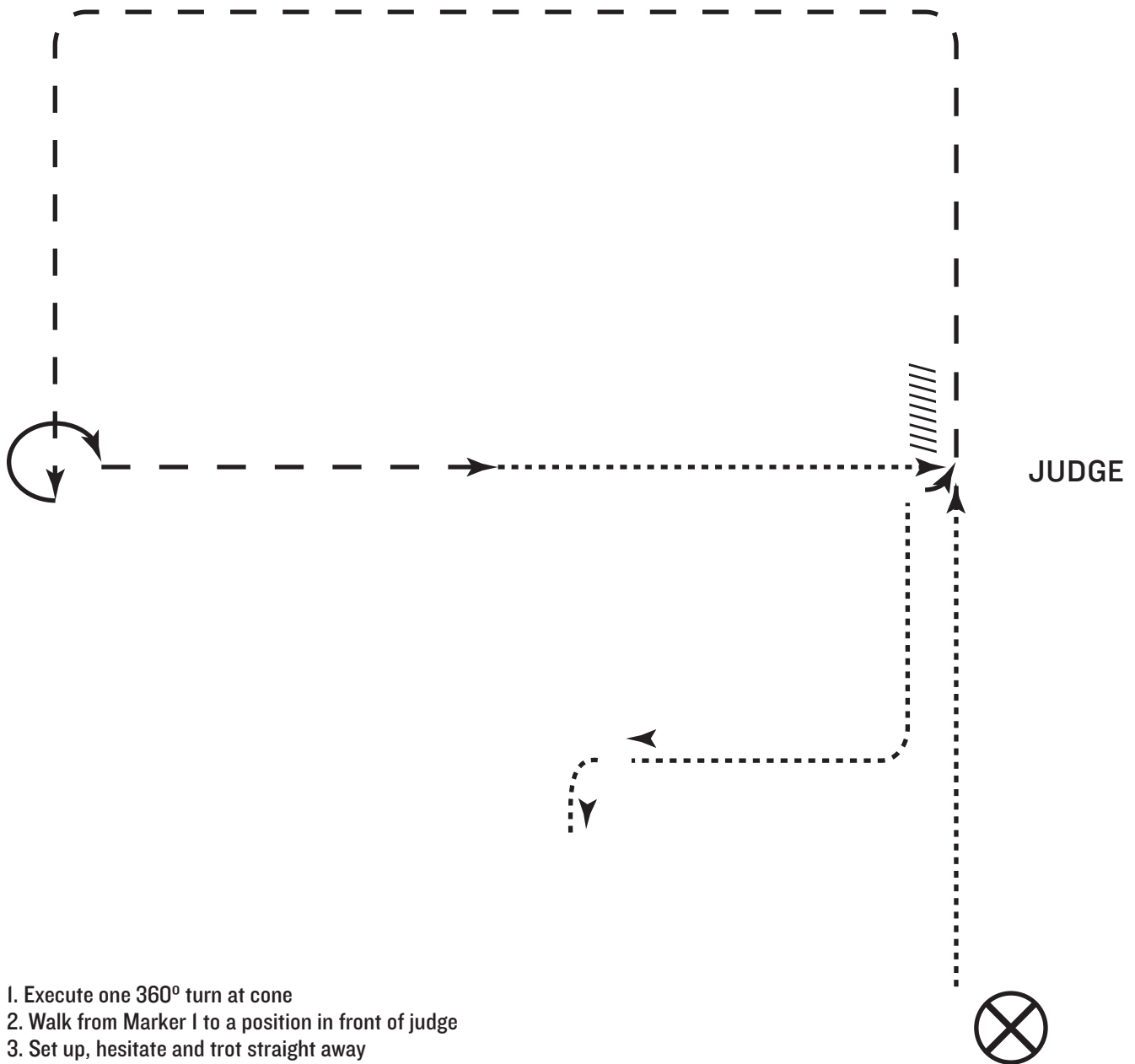

1. Execute one 360° turn at cone
2. Walk from Marker I to a position in front of judge
3. Set up, hesitate and trot straight away
4. Trot two corners and stop
5. Execute 3/4 turn to the right
6. Trot half way to the judge
7. Walk half way to the judge
8. Stop and set up for inspection
9. After inspection, turn 1/4 to the right
10. Back two horse lengths
11. Walk or jog to exit

NOTE: The drawn description of this pattern is only intended for the general depiction of the pattern. Contestants should utilize the arena space to best exhibit their horses.

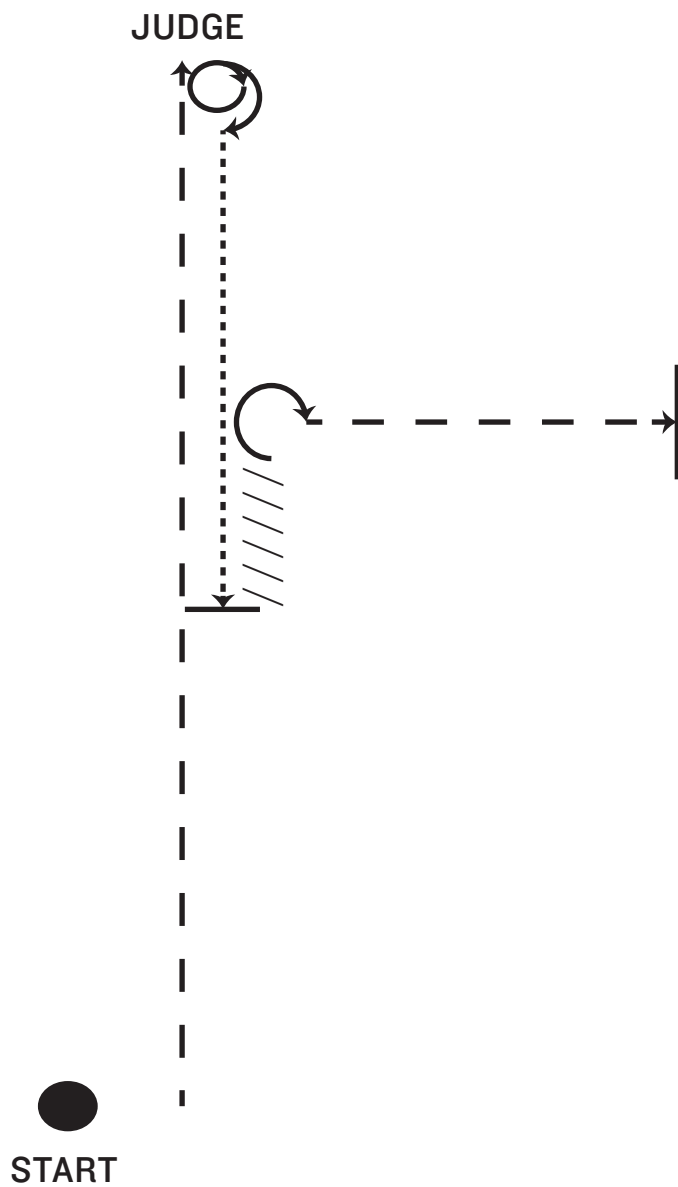

1. Trot to judge
2. Set up for full inspection
3. After inspection, execute 1 1/2 turns and walk half of line
4. Stop, back 2 horse lengths
5. 3/4 turn and trot
6. Halt and set-up. When set up is complete, exit at a walk or jog

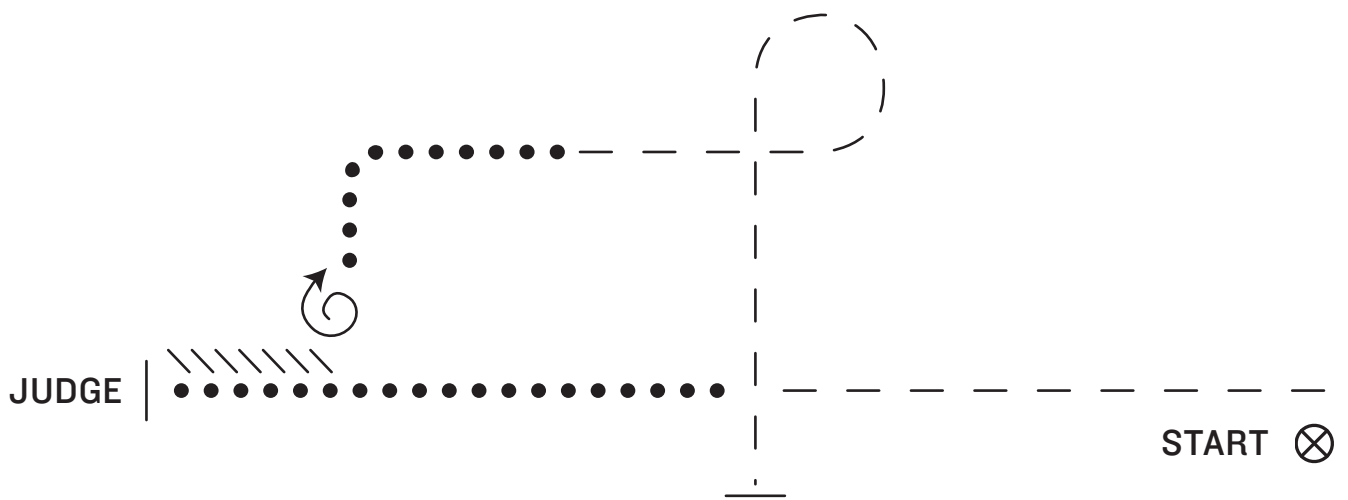

1. Trot half way, walk half way
2. Stop and set-up for full inspection
3. After inspection, back 2 horse lengths, execute 1/4 turn
4. Walk. Trot a left circle and across initial line
5. Stop and set-up for brief inspection
6. Exit at a walk or trot

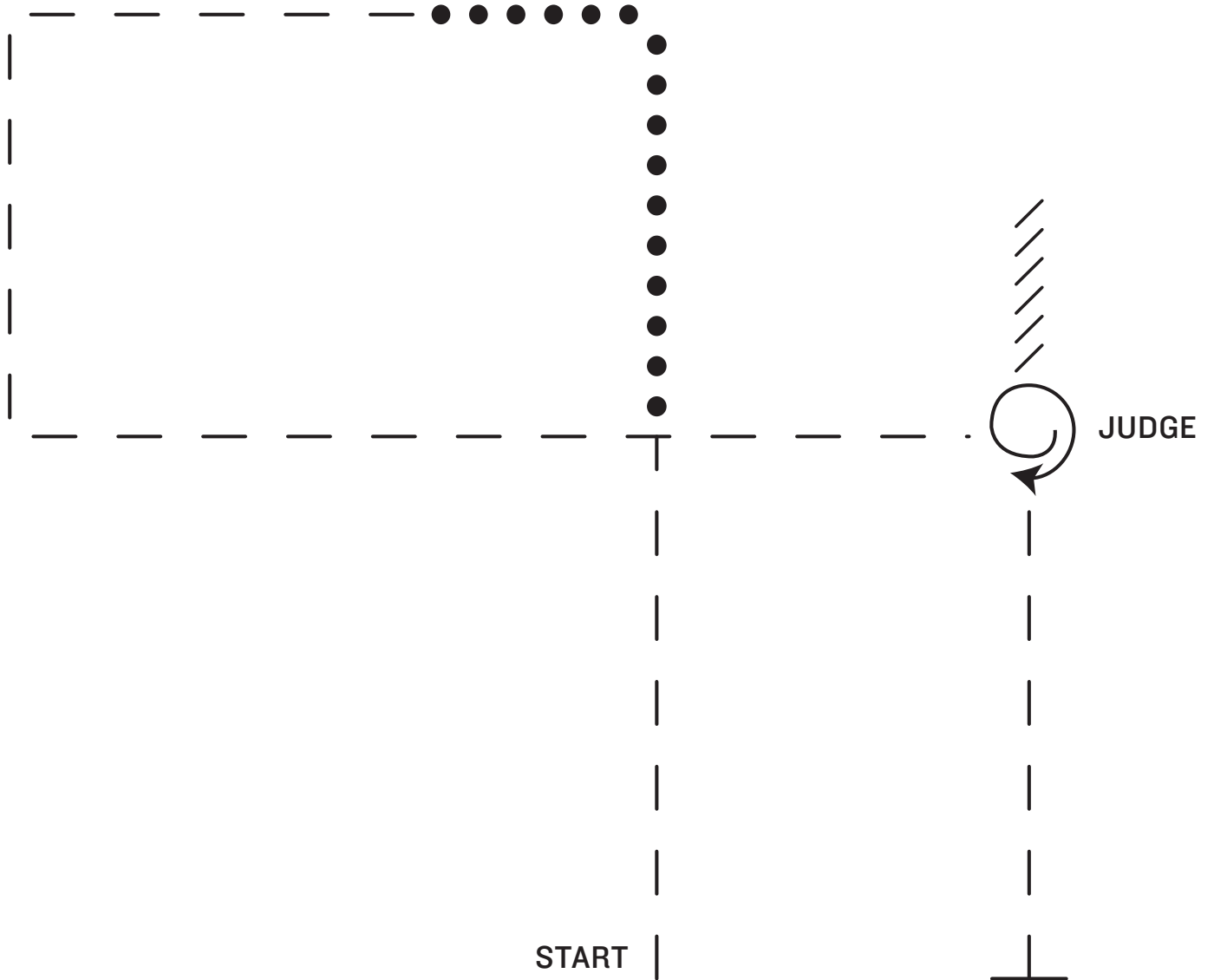

1. Trot until even with judge
2. Walk for 3 horse lengths and walk a corner
3. Trot 3 horse lengths, trot corner, continue trotting and trot corner to judge
4. Stop 1/4 turn
5. Set up for inspection
6. Back 1 horse length and trot out
7. Stop even with cone
8. Exit at a walk or trot

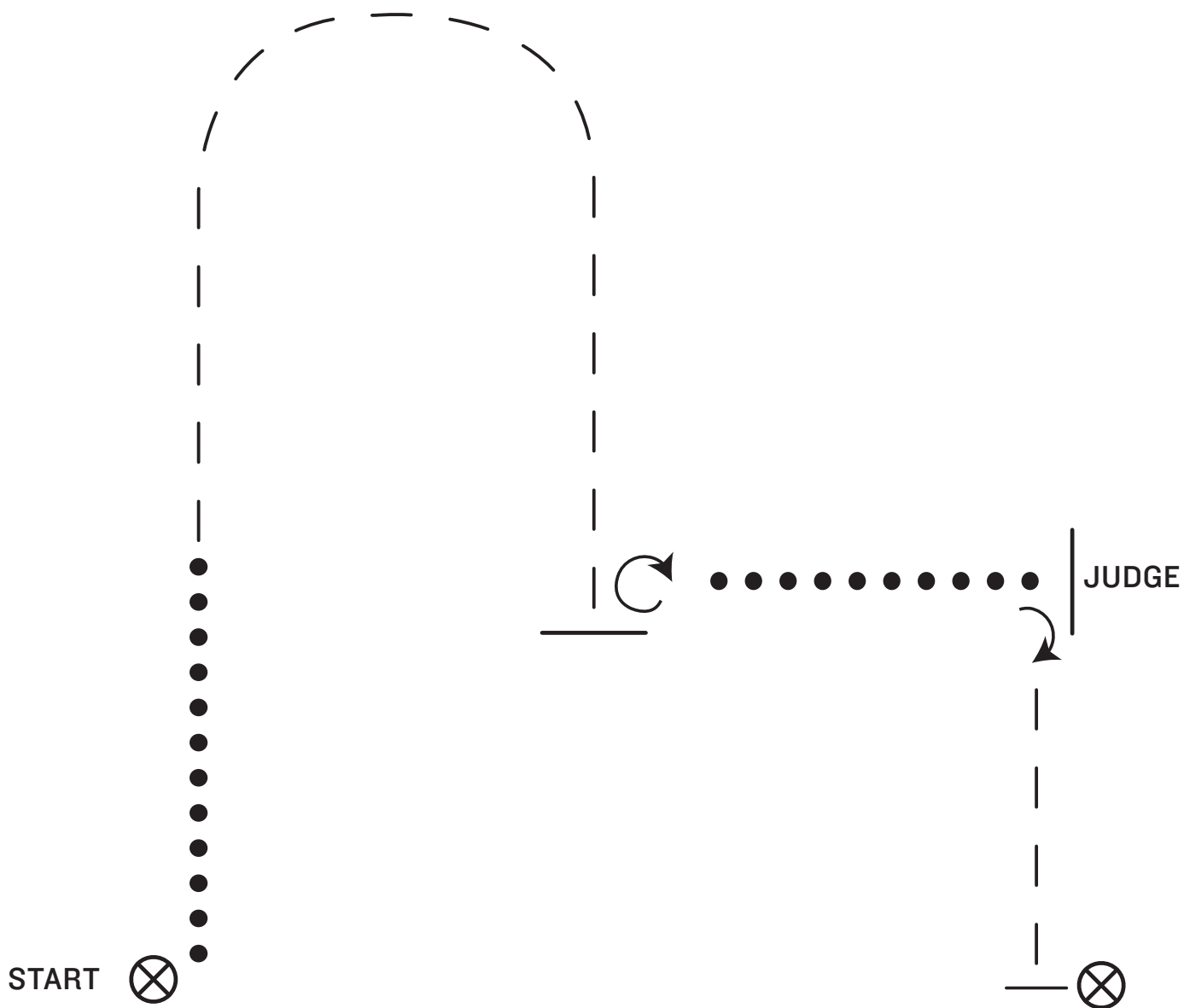

1. Walk half line
2. Trot around end and down line
3. Halt and execute a 3/4 turn
4. Walk to judge
5. Set up for inspection
6. After inspection, 1/4 turn and trot to marker, stop
7. Exit at a walk or trot

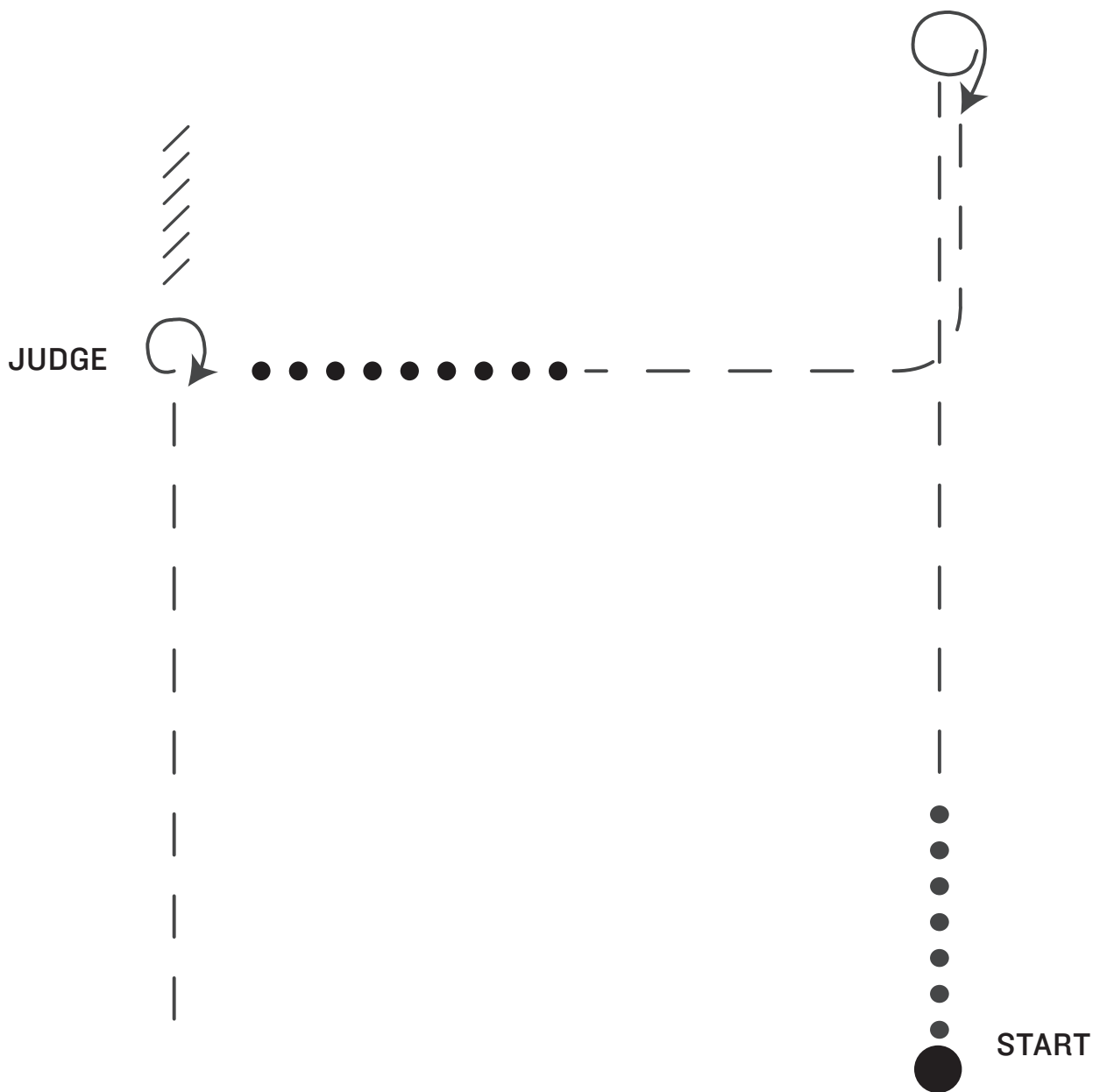

1. Be ready at cone. Walk one-third of the distance of your line
2. Trot to the end of your line
3. Stop and execute 1 1/2 turns
4. Trot down line and turn toward the judge. After making the corner, trot half way to the judge
5. Walk to the judge and set up
6. Inspection
7. After inspection, execute a 3/4 turn
8. Back approximately 2 horse lengths and exit at the trot

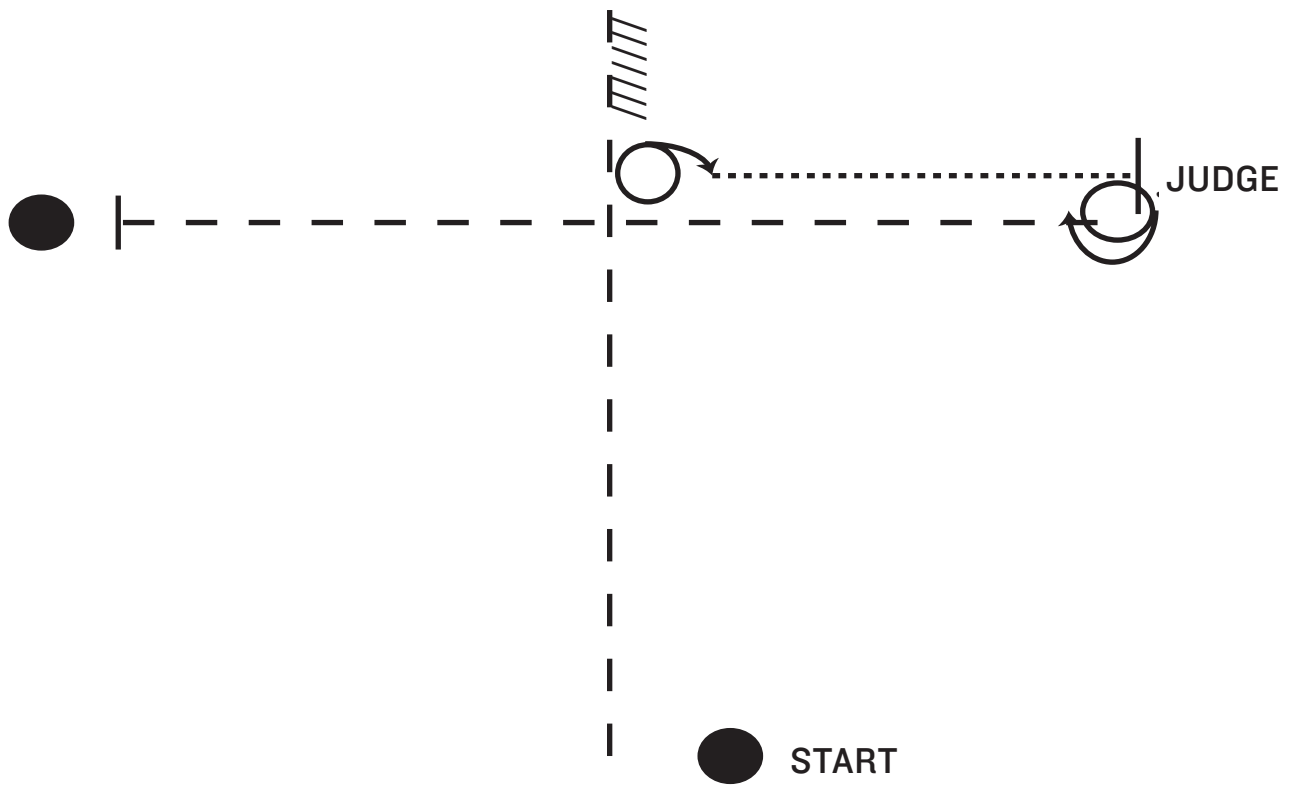

1. Trot past judge. Stop
2. Back; execute 1 1/4 turns
3. Walk to judge; set up for inspection
4. 1 1/2 turns; trot to cone; stop and set up
5. Exit at a walk or trot

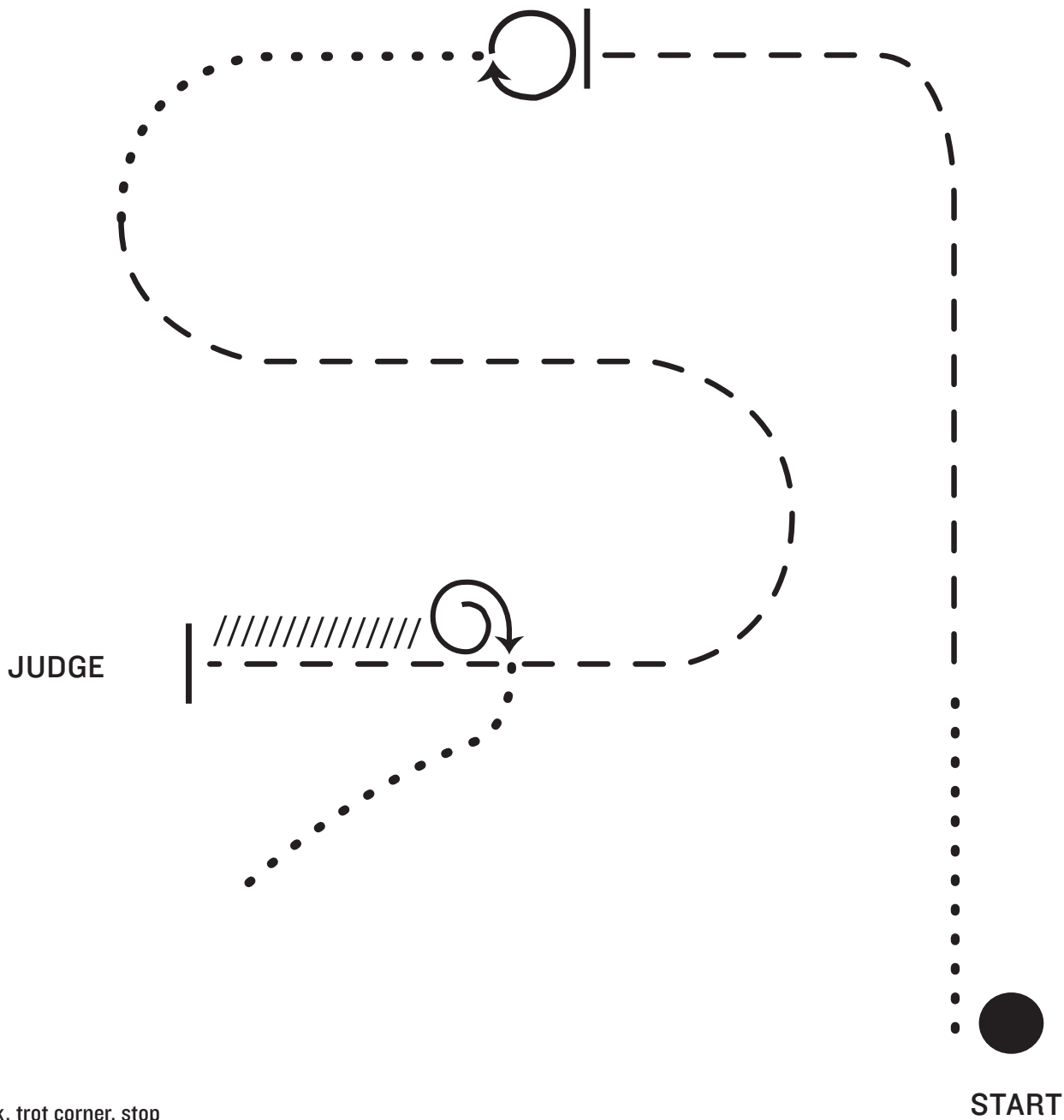

1. Walk, trot corner, stop
2. 360° turn
3. Walk, trot serpentine
4. Stop, set up for inspection
5. After inspection, back 15 feet
6. 1 3/4 turns and exit at a walk or trot

Note: The drawn description of this pattern is only intended for the general depictions of the pattern. Contestants should utilize the arena space to best exhibit their horses.

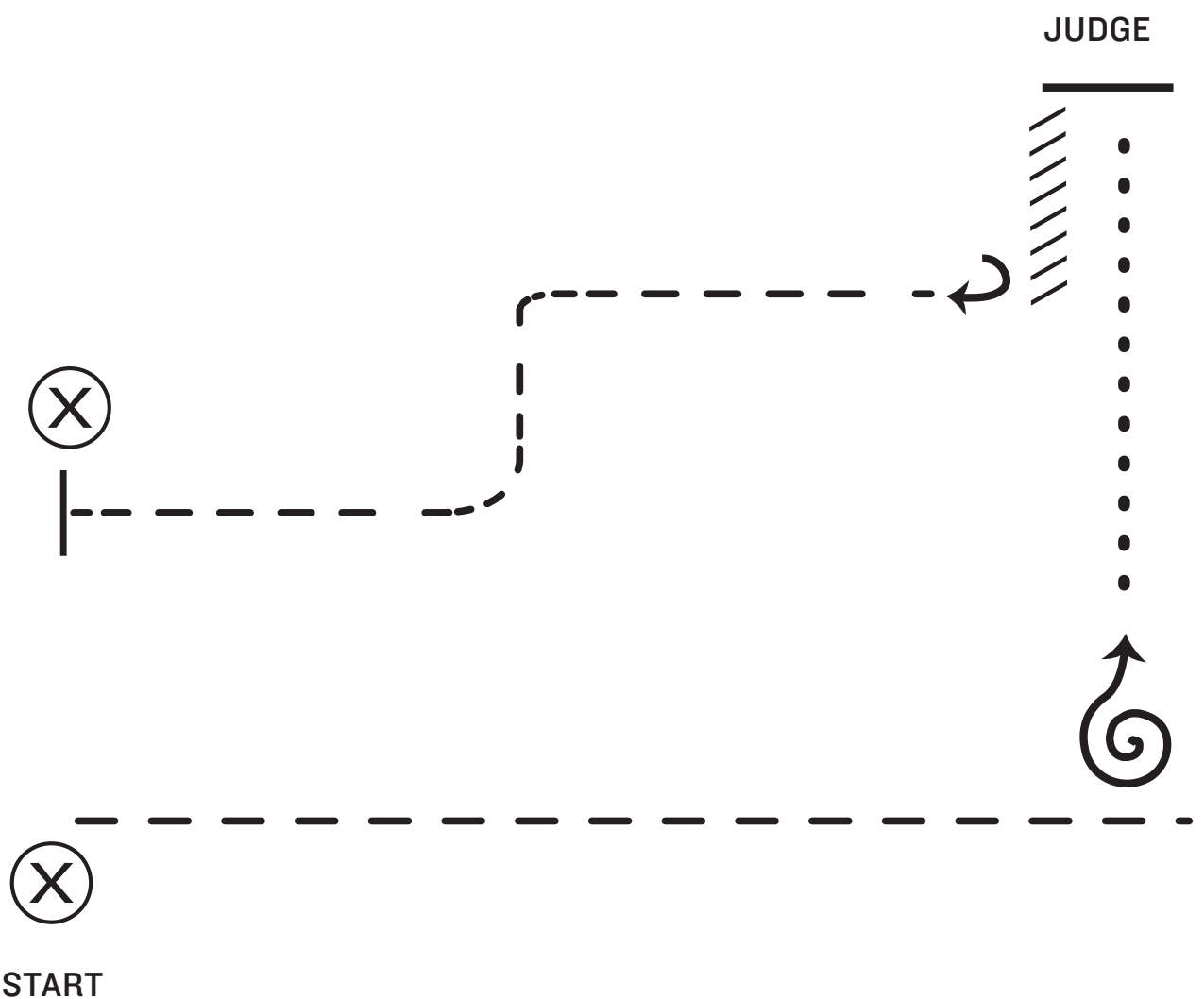

1. Trot across arena. Stop
2. 1 3/4 turn
3. Walk to judge
4. Set up for inspection
5. After inspection, back 2 horse lengths
6. 3/4 turn
7. Trot as shown. Stop
8. Exit at a walk or trot along arena wall

NOTE: The drawn description of this pattern is only intended for the general depiction of the pattern. Contestants should utilize the arena space to best exhibit their horses.

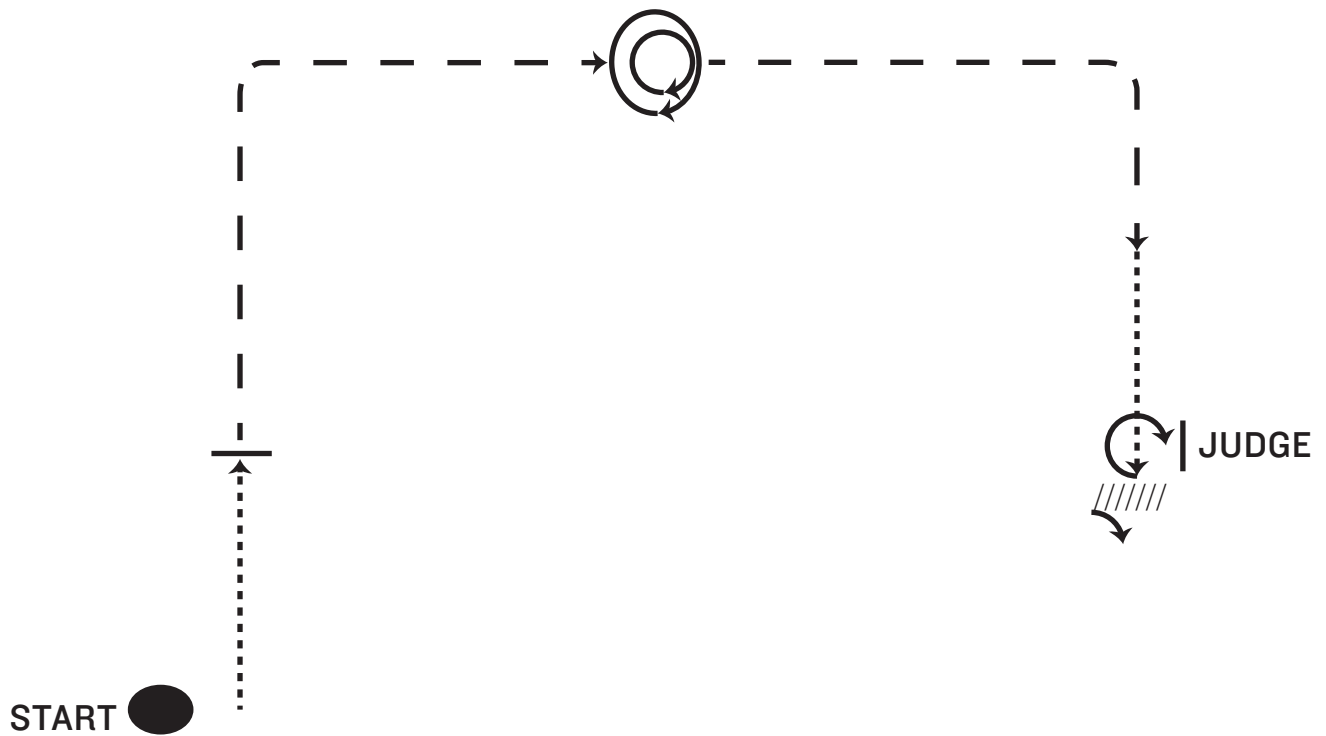

1. Walk. When across from judge, stop and set-up horse for brief inspection
2. Trot corner. Halt, execute two turns
3. Trot corner, walk, halt, 270° turn
4. Set up for full inspection
5. Back. 1/4 turn and exit at a walk or trot

NOTE: The drawn description of this pattern is only intended for the general depiction of the pattern. Contestants should utilize the arena space to best exhibit their horses.

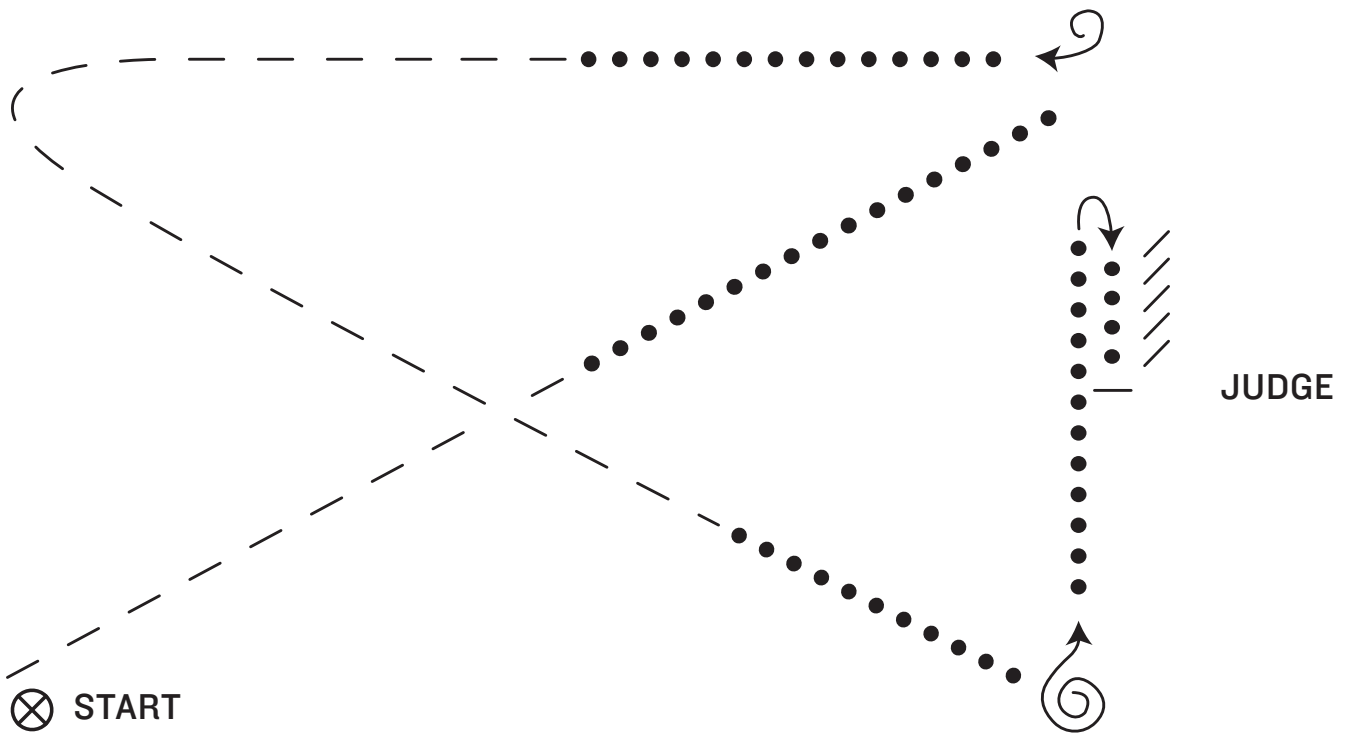

1. Trot half of the way, walk half of the way
2. Turn, walk half of the way, trot corner and three-quarters of the way
3. Walk, 1 3/4 turns
4. Walk past judge, 180° turn
5. Walk, stop with hindquarters in line with judge for full inspection
6. Back 2 horse lengths, exit at a walk or trot

NOTE: The drawn description of this pattern is only intended for the general depiction of the pattern. Exhibitors should utilize the arena space to best exhibit their horses.

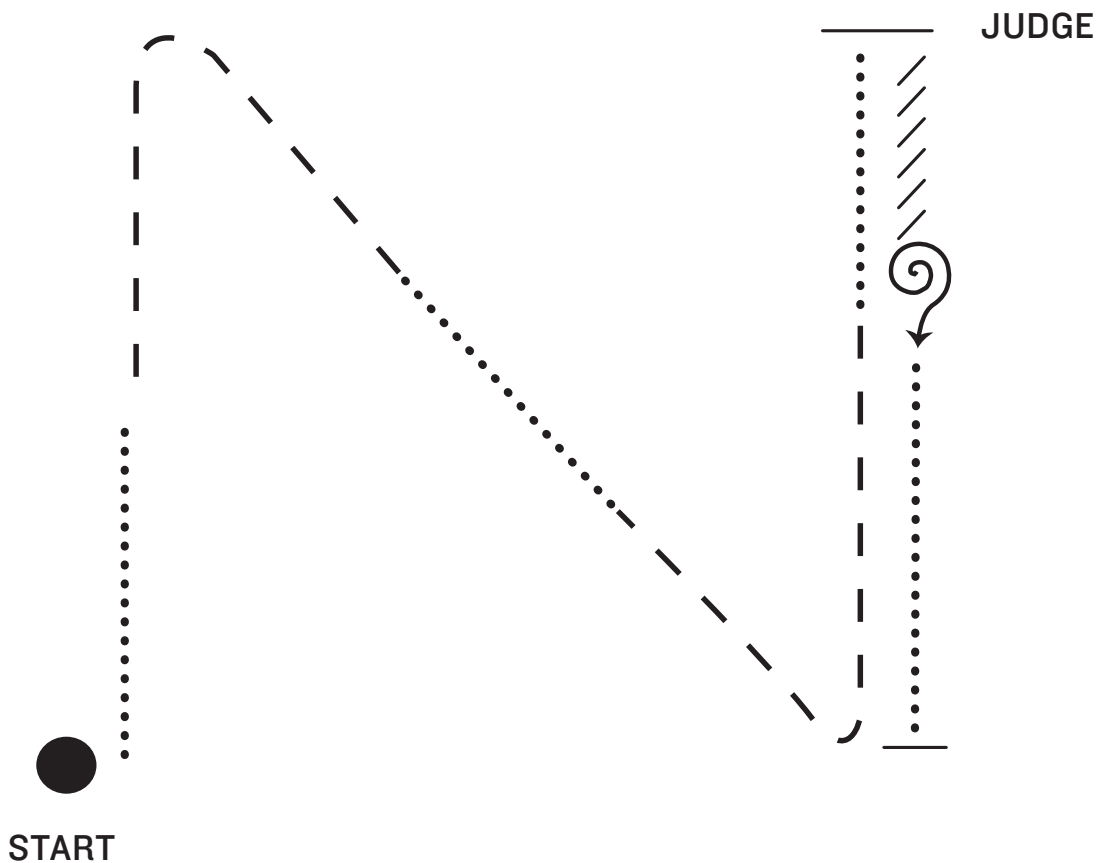

1. Walk half of line
2. Trot corner and one-third of line
3. Walk one-third of line
4. Trot one-third of line, corner and half line
5. Walk half of line
6. Stop and set up inspection with horse's shoulder across from judge
7. After inspection, back 15 feet
8. Execute 1 1/2 turns and walk; stop across from start cone
9. Exit at a walk or jog

NOTE: The drawn description of this pattern is only intended for the general depictions of the pattern. Contestants should utilize the arena space to best exhibit their horses.

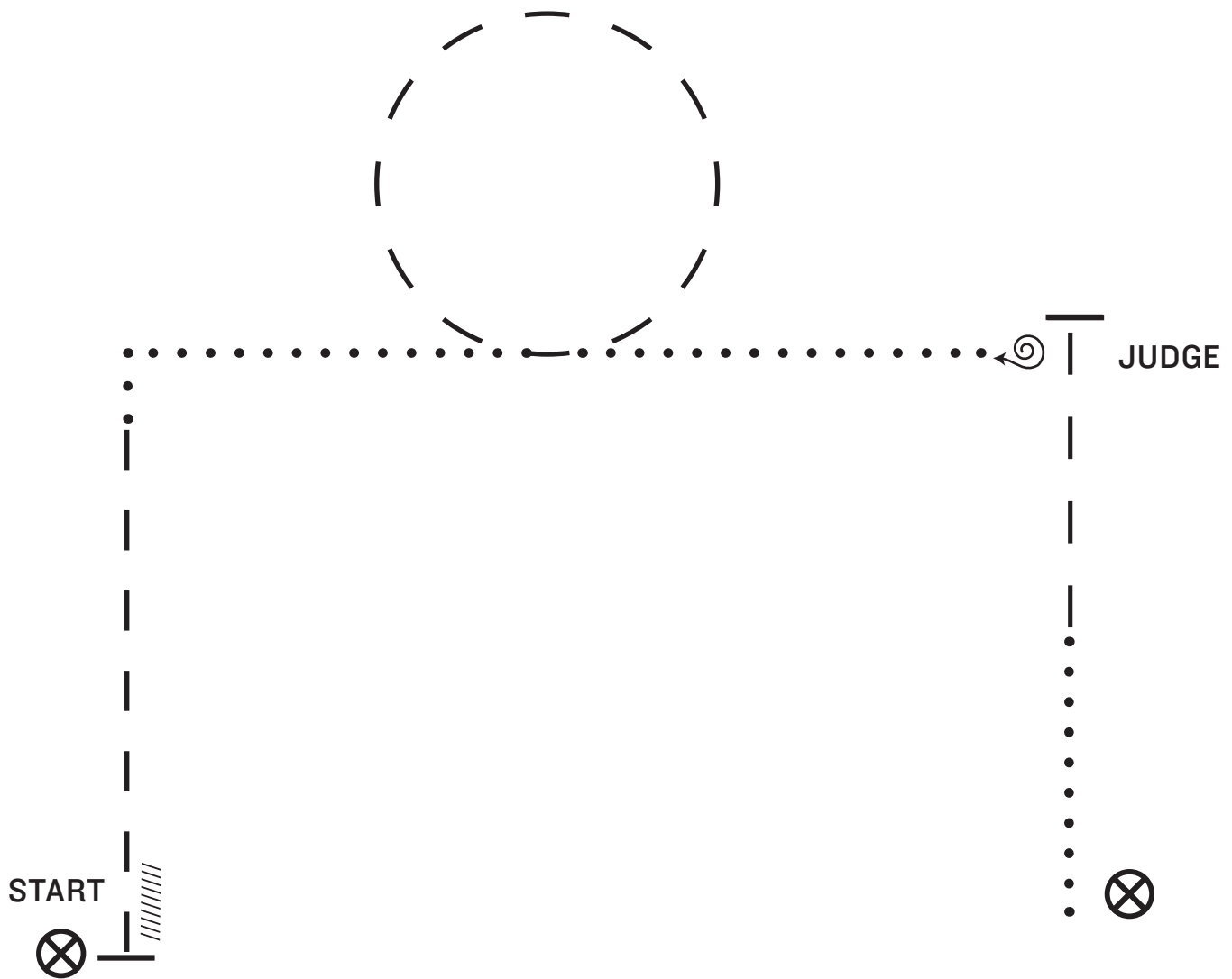

1. Walk
2. Trot, stop with horse's shoulder even with judge
3. Set-up for inspection. After inspection, judge will move to horse's hip
4. 1 3/4 turn
5. Walk to center
6. Trot circle
7. Walk corner
8. Trot to end, stop
9. Back 2 horse lengths, hesitate
10. Exit at walk or trot

NOTE: The drawn description of this pattern is only intended for the general depiction of the pattern. Contestants should utilize the arena space to best exhibit their horses.

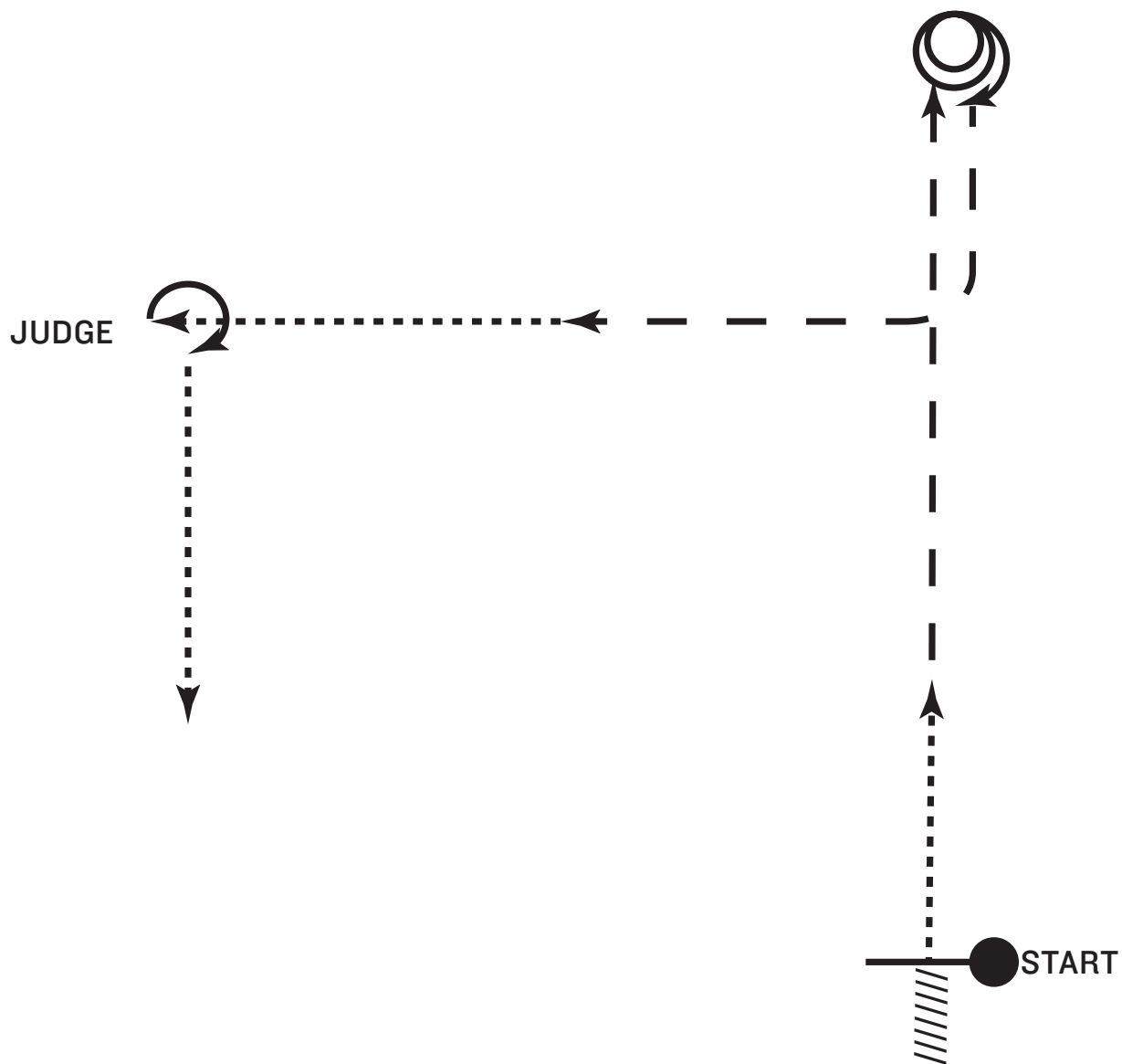

1. Be ready at cone
2. Back 10-12 feet
3. Walk approximately one-third of the distance of your line
4. Trot to the end of your line
5. Stop and execute 2 1/2 turns
6. Trot down line and turn toward the judge
7. After making the corner, trot half way to the judge
8. Walk to the judge
9. Set up for inspection
10. After inspection, execute a 3/4 turn and walk or jog to the exit

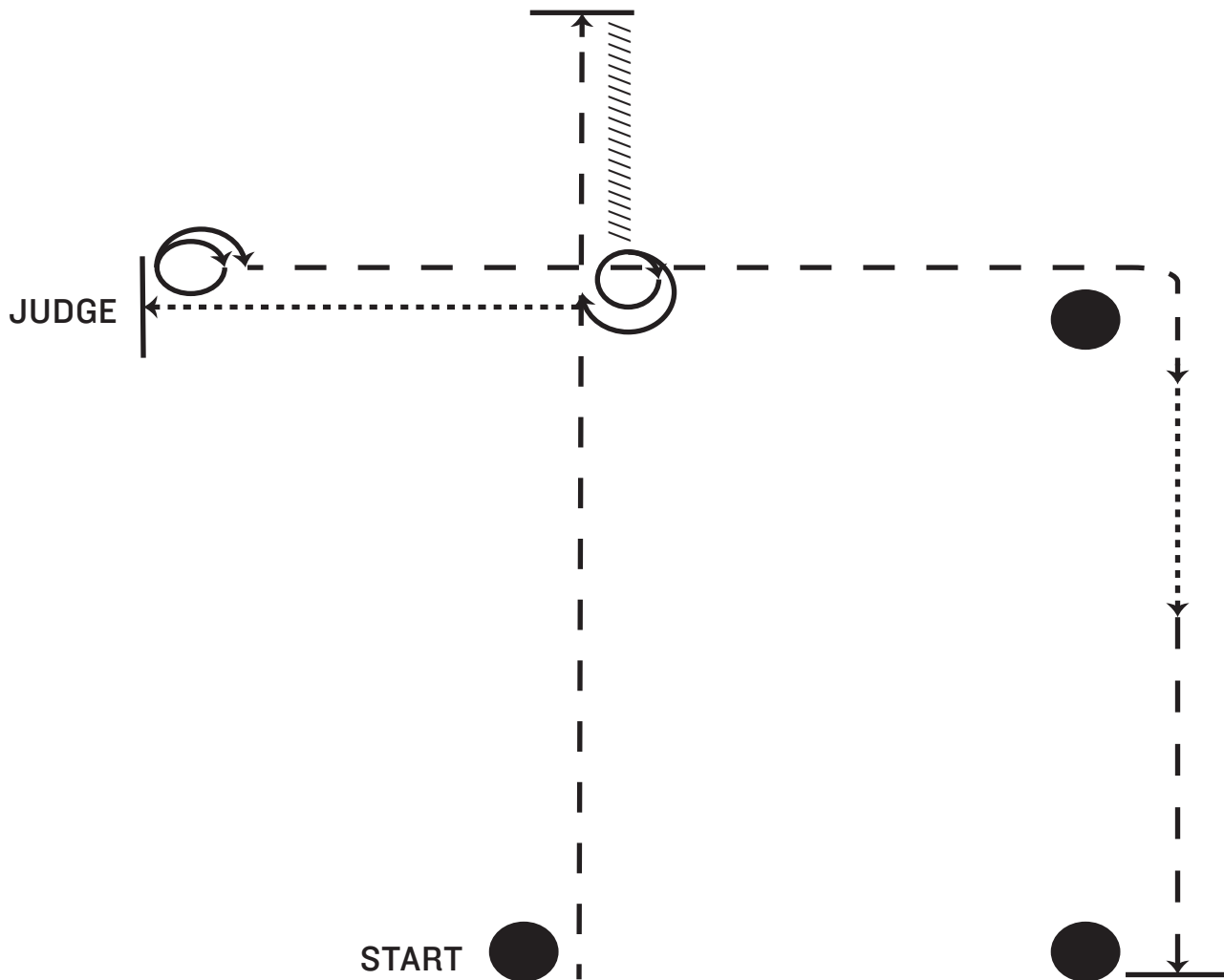

1. Trot; stop and back
2. Execute 1 3/4 turns; walk to judge
3. Set up for inspection
4. After inspection, execute 1 1/2 turns; trot away and around corner
5. Walk half of line; trot half of line; stop
6. Exit at a walk or jog

NOTE: The drawn description of this pattern is only intended for the general depiction of the pattern. Contestants should utilize the arena space to best exhibit their horses.

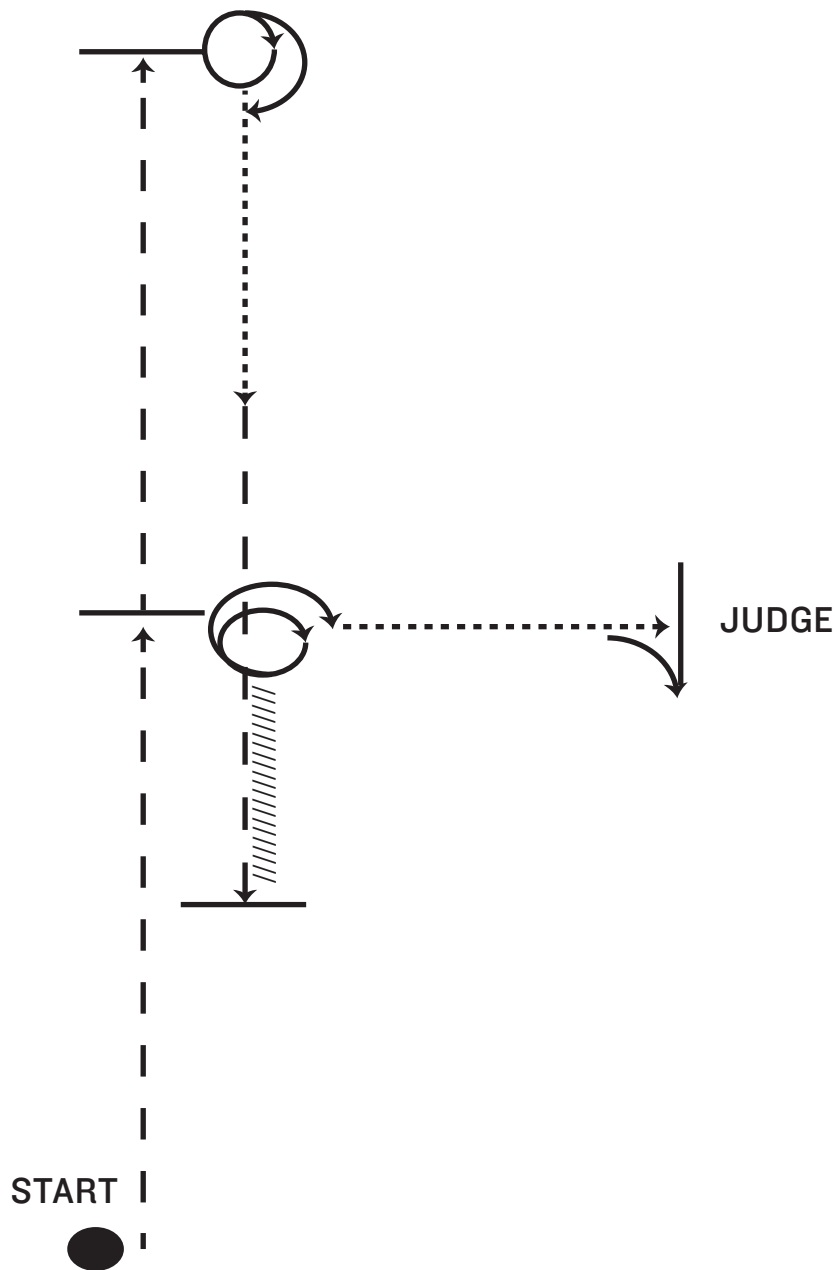

1. Trot half of the line. Halt (no set-up). Trot remainder of line
2. 1 1/2 turn, walk one-third of the line.
3. Trot, stop
4. Back, 1 3/4 turn, walk to judge
5. Set up for inspection, after inspection, turn 1/4 turn
6. Exit

NOTE: The drawn description of this pattern is only intended for the general depiction of the pattern. Contestants should utilize the arena space to best exhibit their horses.

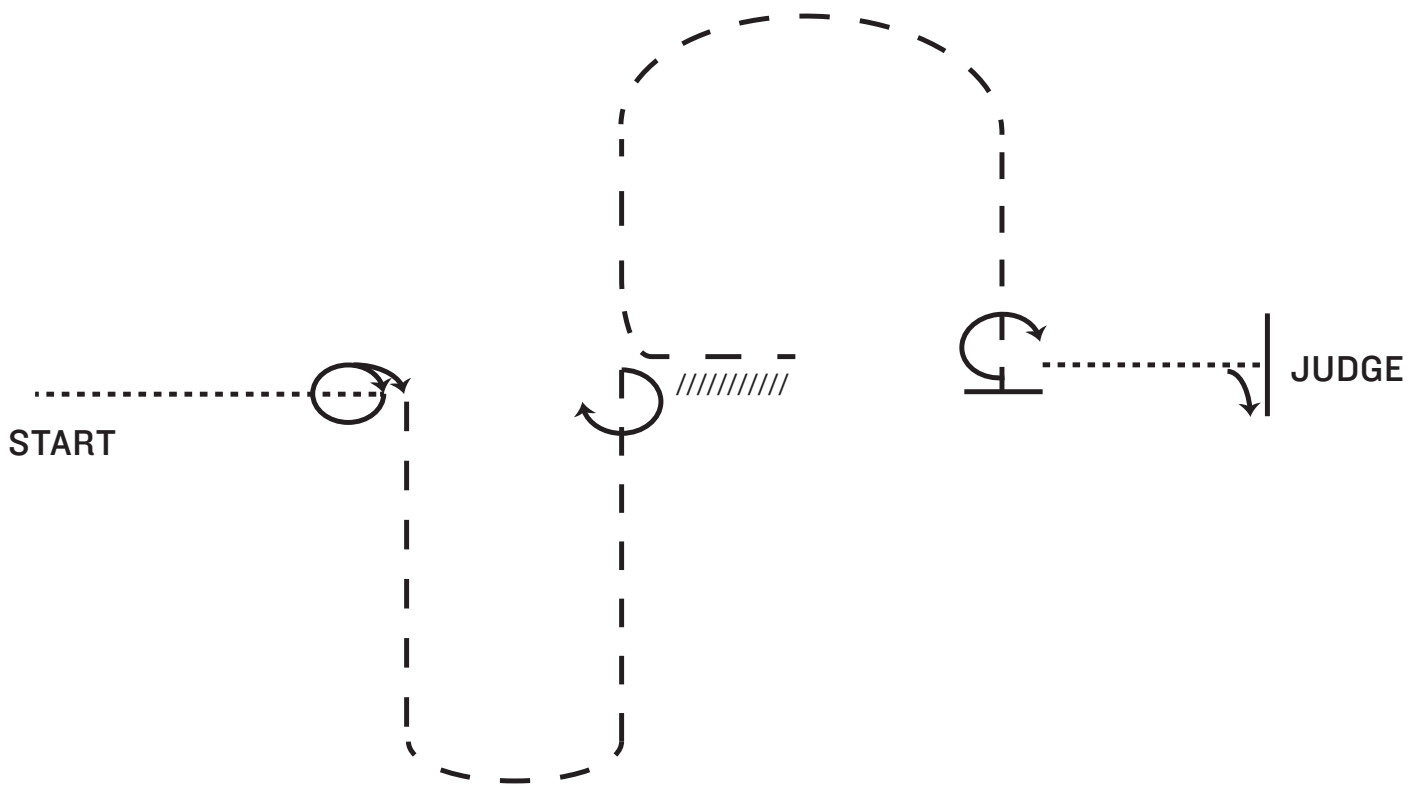

1. Walk, 1 1/4 turn
2. Trot
3. Stop. 3/4 turn, back 2 horse lengths
4. Trot
5. Stop, 3/4 turn, walk to judge
6. Set up for inspection
7. After inspection, 1/4 turn then exit at a walk or trot

NOTE: The drawn description of this pattern is only intended for the general depiction of the pattern. Exhibitors should utilize the arena space to best exhibit their horses.

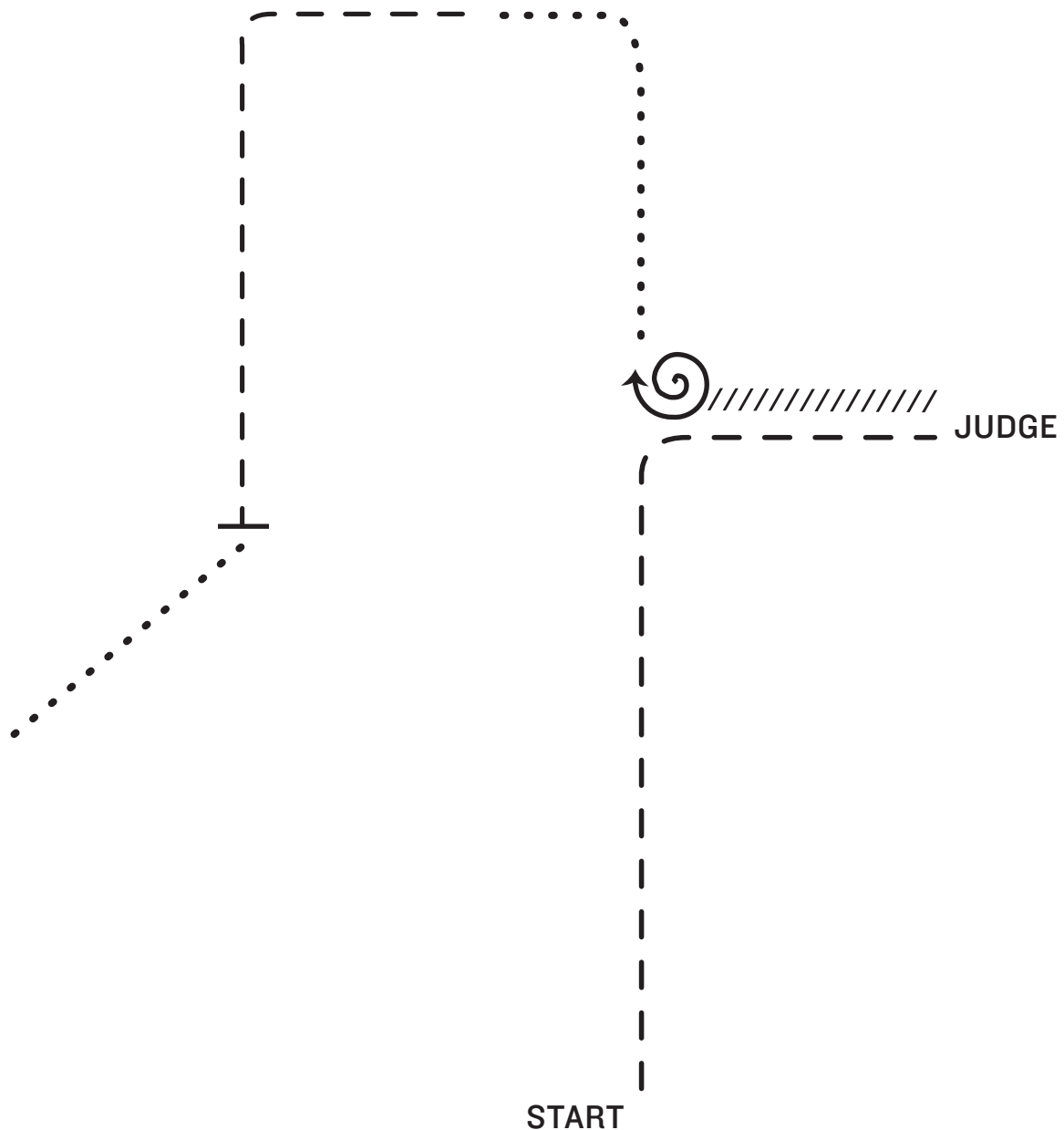

1. Trot down the arena and to the judge
2. Set-up for inspection
3. Back
4. 1 3/4 turn
5. Walk
6. Trot
7. Stop; set up
8. When dismissed, exit at a walk or trot

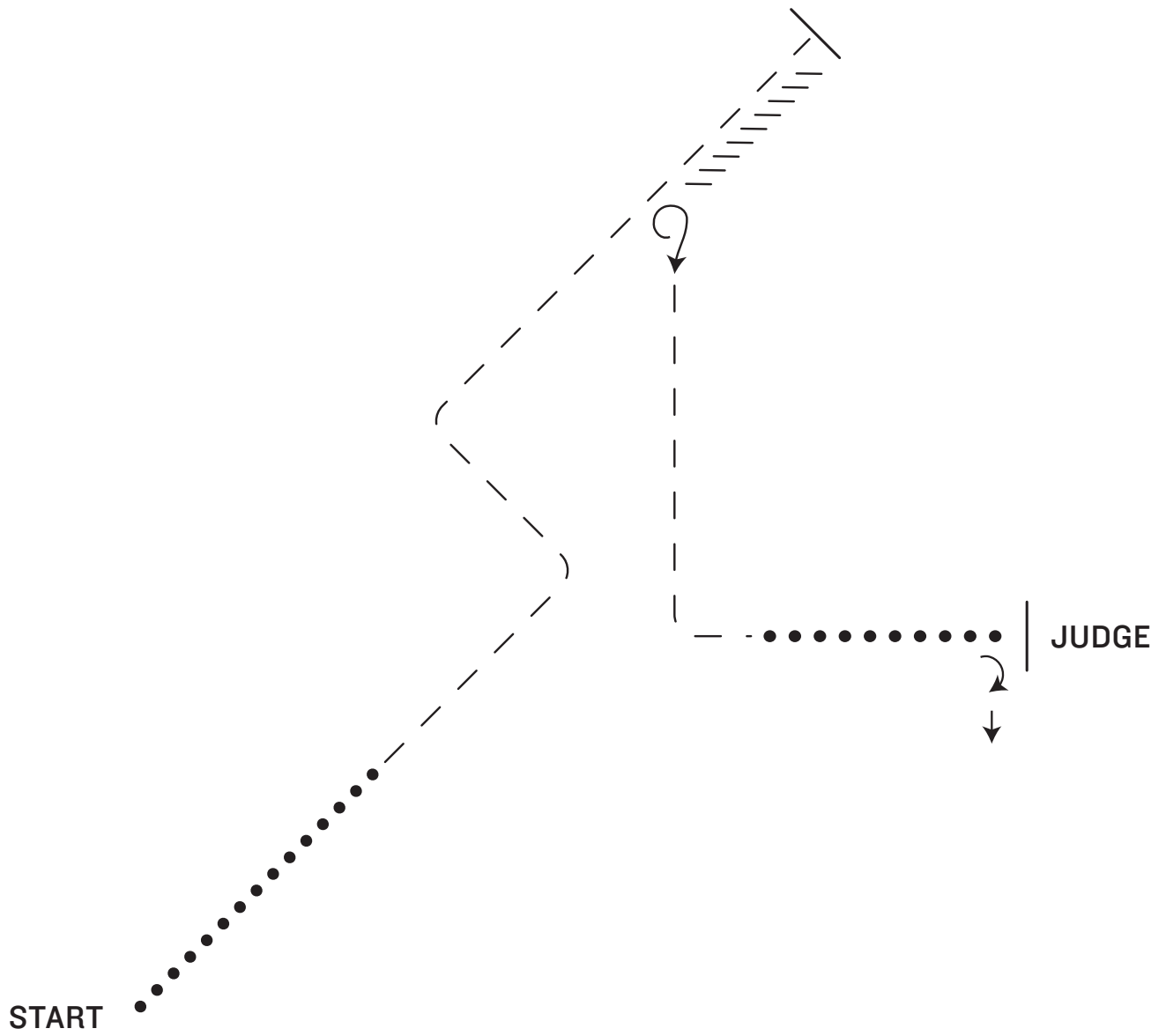

1. Walk
2. Trot
3. Stop and back
4. 1 3/8 turn
5. Trot
6. Walk to judge
7. Set up for inspection
8. After inspection, 1/4 turn and exit at a walk or trot

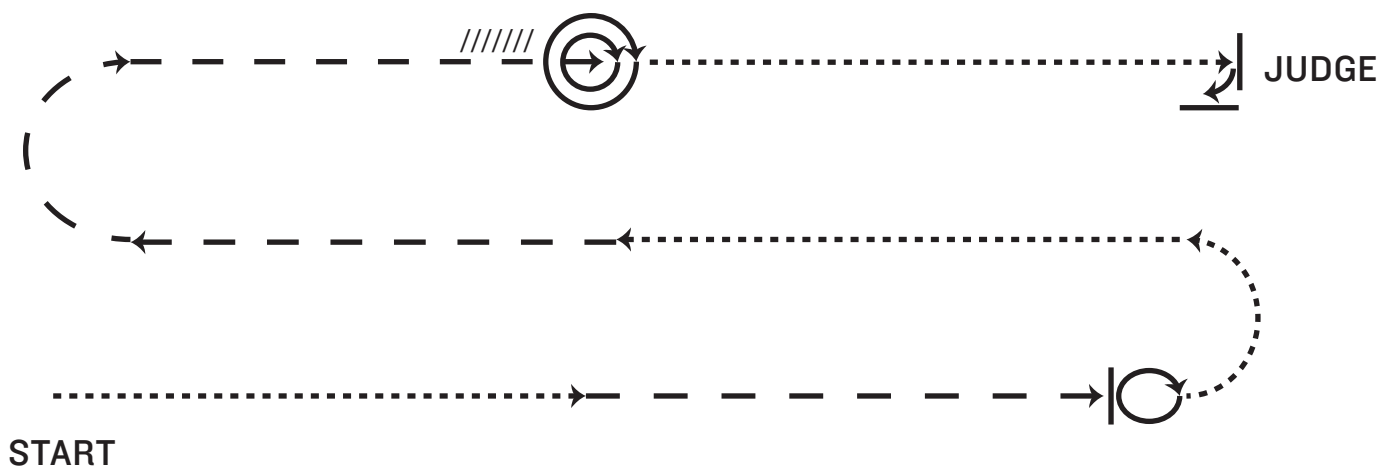

1. Walk half of line; trot half of line. Stop. Execute a 360° turn
2. Walk; trot; stop
3. Execute 2 turns; back 2 horse lengths
4. Walk to judge; set-up for brief inspection
5. Execute 1/4 turn and set-up for full inspection
6. Exit at a walk or jog

NOTE: The drawn description of this pattern is only intended for the general depiction of the pattern. Contestants should utilize the arena space to best exhibit their horses.

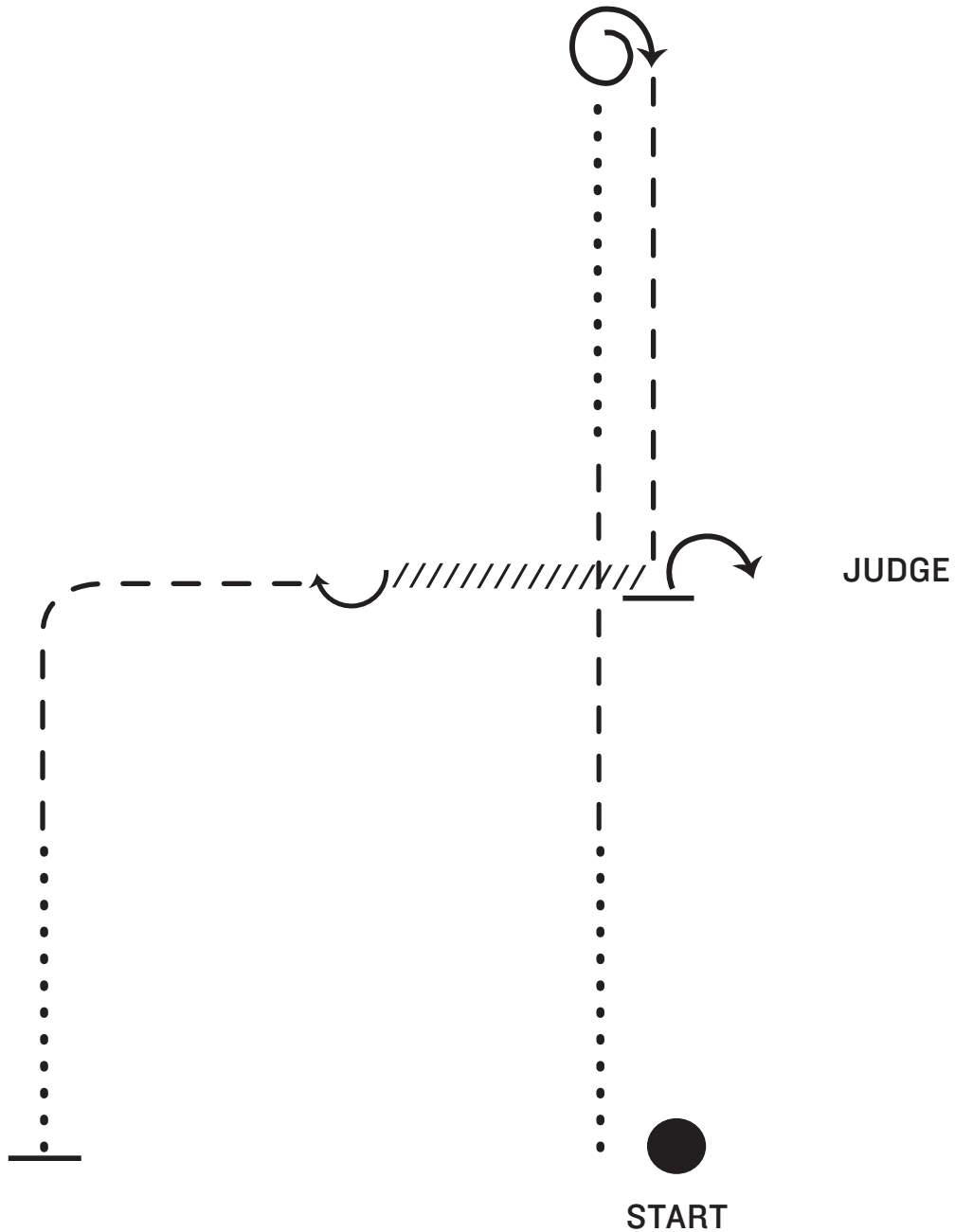

1. In equal thirds, walk, trot and walk the line
2. Execute 1 1/2 turn
3. Trot, stop, 3/4 turn
4. Set up for inspection
5. After inspection, back 15 feet, 1/2 turn
6. Trot corner, walk, stop and set up
7. Exit at a walk or trot

Note: The drawn description of this pattern is only intended for the general depictions of the pattern. Contestants should utilize the arena space to best exhibit their horses.

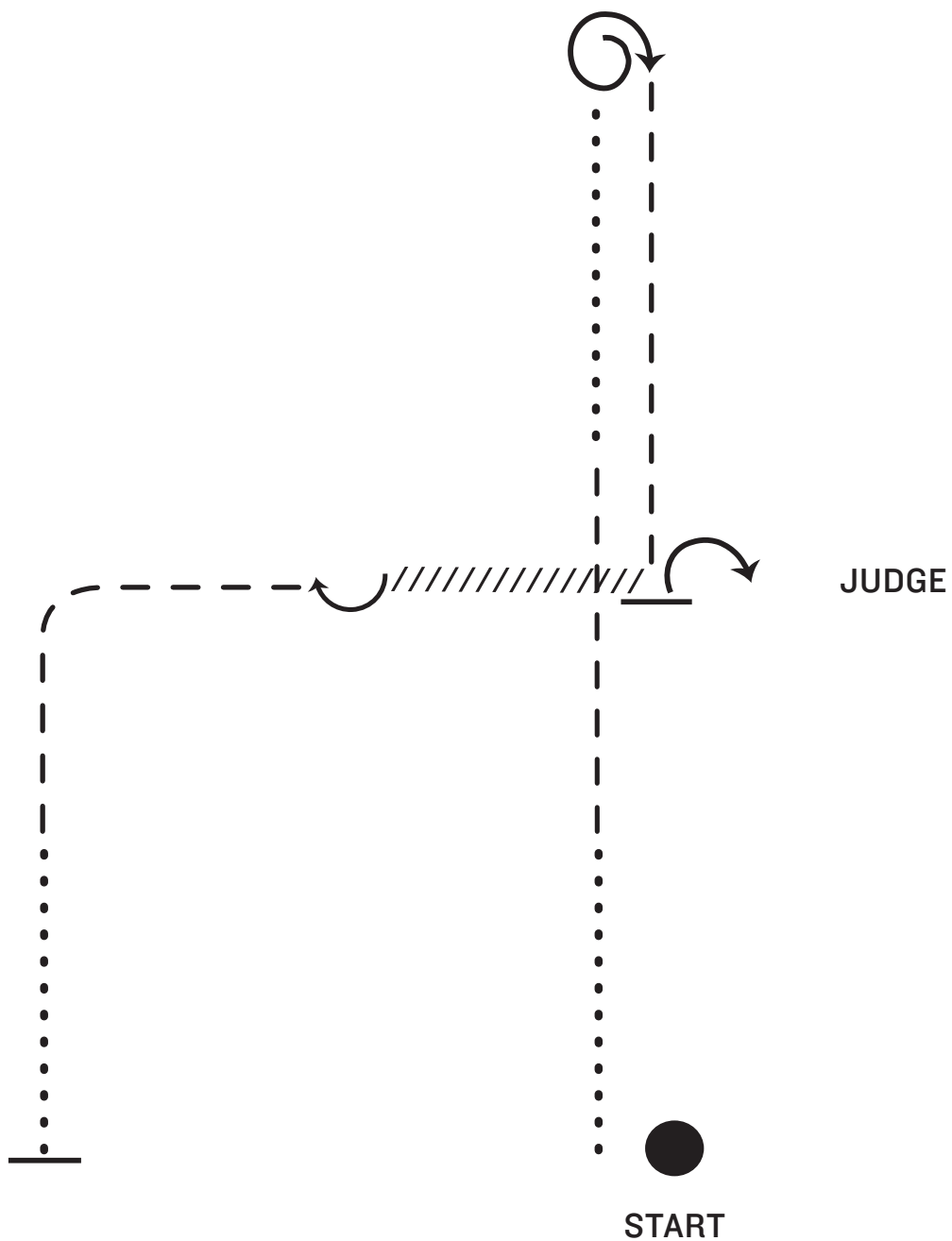

1. In equal thirds, walk, trot and walk the line
2. Execute 1/2 turn
3. Trot, stop, 3/4 turn
4. Set up for inspection
5. After inspection, back 15 feet, 1/2 turn
6. Trot corner, walk, stop and set up
7. Exit at a walk or trot

Note: The drawn description of this pattern is only intended for the general depictions of the pattern. Contestants should utilize the arena space to best exhibit their horses.

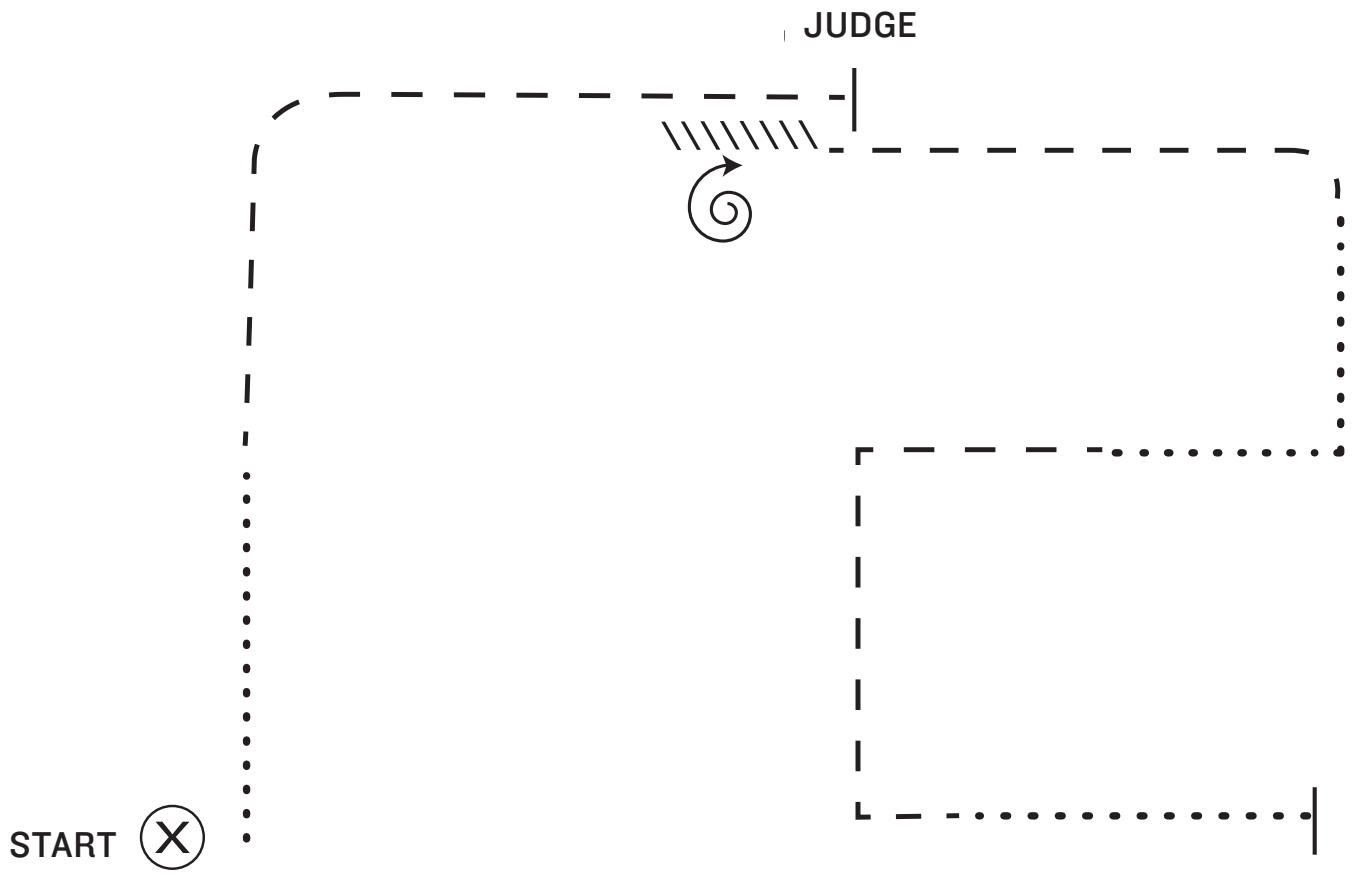

1. Walk
2. Trot to judge
3. Stop with hip at the judge and set up for inspection
4. Back 2 horse lengths
5. 2 turns
6. Trot corner
7. Walk corner
8. Trot 2 corners
9. Walk, stop and set up
10. Exit at a walk or trot

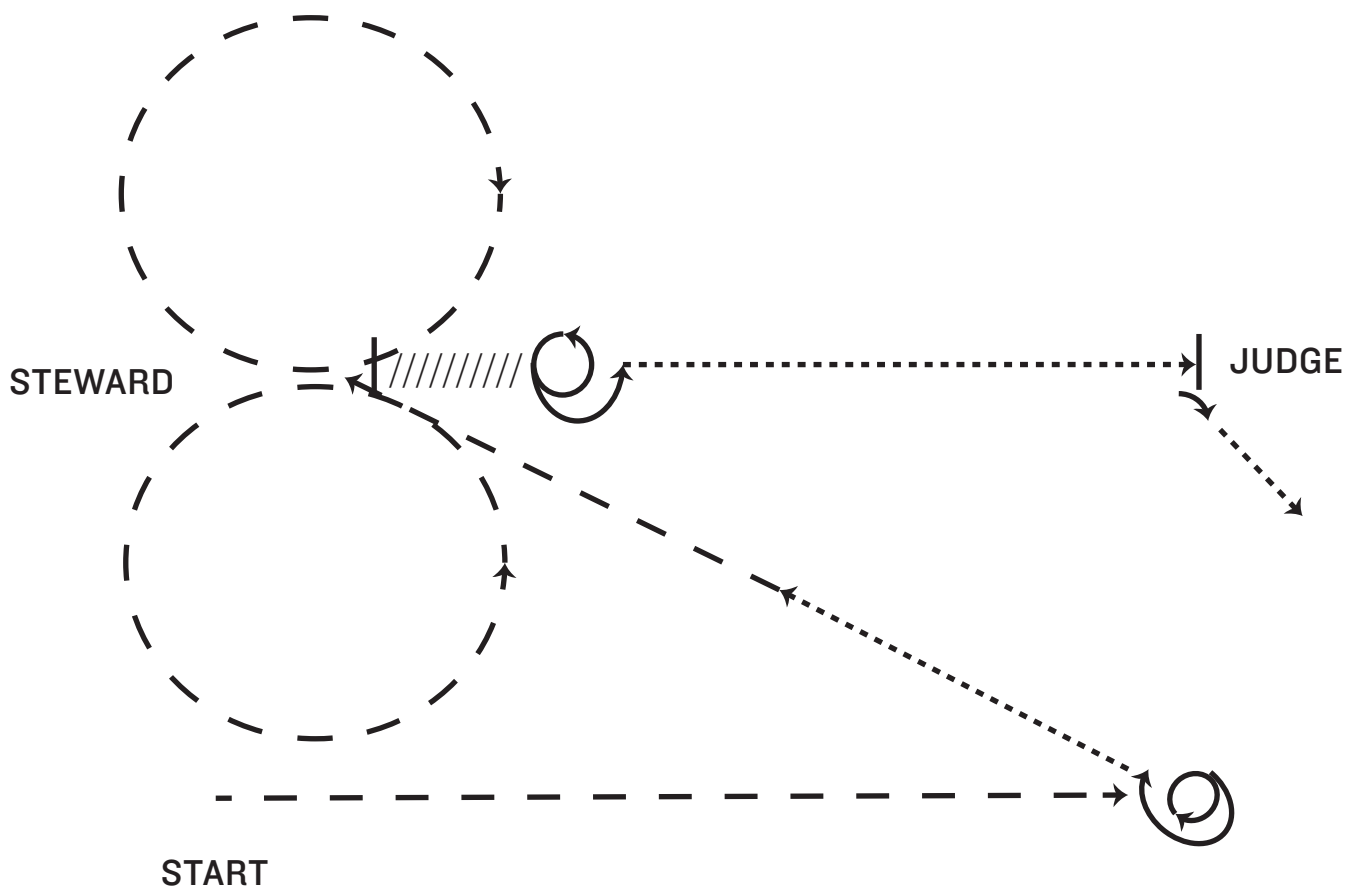

1. Trot across arena. Stop and execute 1/2 turn
2. Walk half of the line. Trot across arena
3. Trot a circle to the left and then to the right, equal sized
4. Stop and back
5. Execute 1/2 turn and walk to judge
6. Set up for inspection
7. Exit at a walk or trot

NOTE: The drawn description of this pattern is only intended for the general depiction of the pattern. Contestants should utilize the arena space to best exhibit their horses.

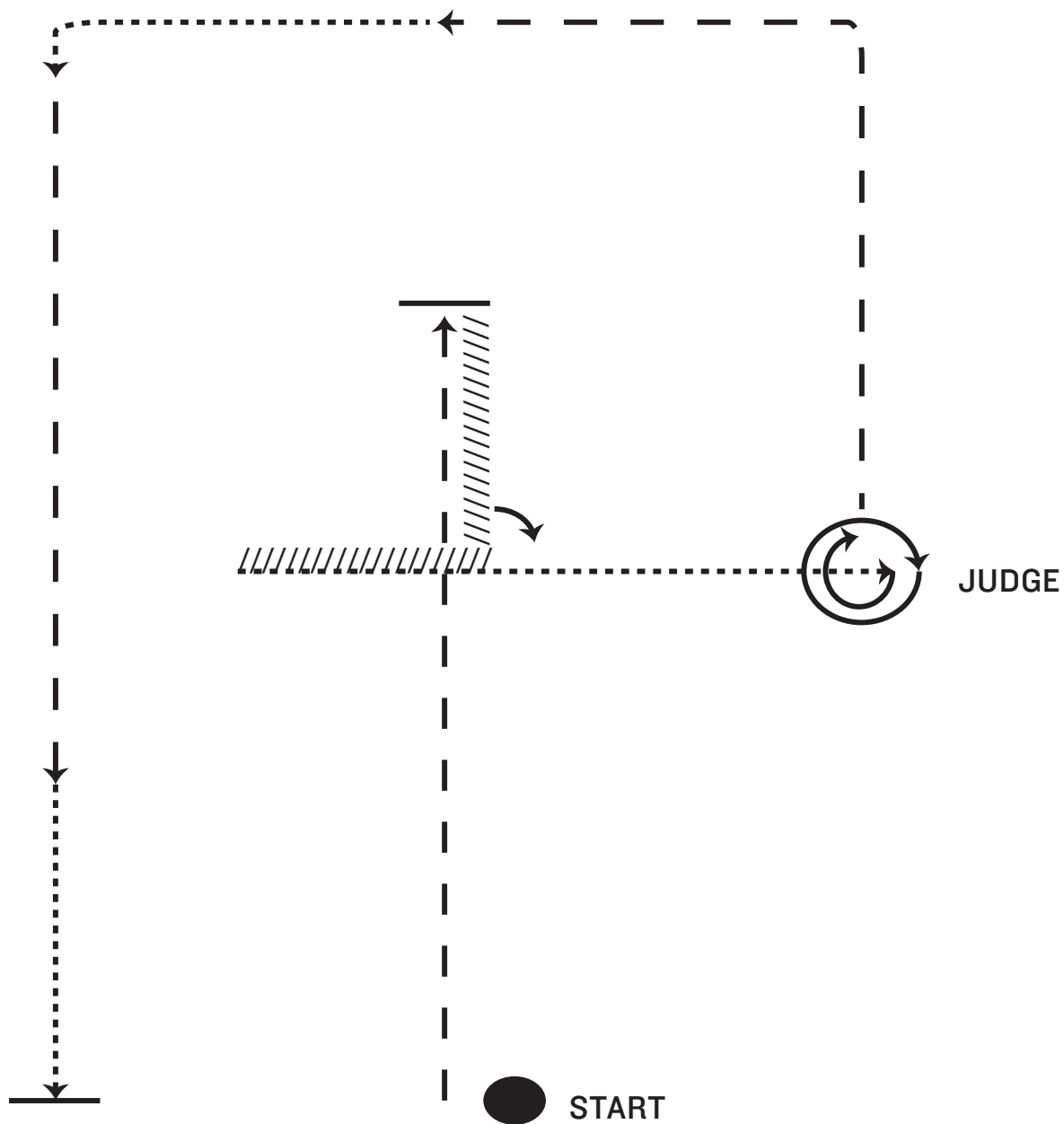

1. Trot past judge. Stop
2. Back, 1/4 turn right, back
3. Walk to judge, set-up for full inspection
4. Turn 3/4 turn, set-up for brief inspection, then 1 full turn
5. Trot around corner, walk, trot 2/3 of line, walk, stop to end pattern

NOTE: The drawn description of this pattern is only intended for the general depiction of the pattern. Contestants should utilize the arena space to best exhibit their horses.

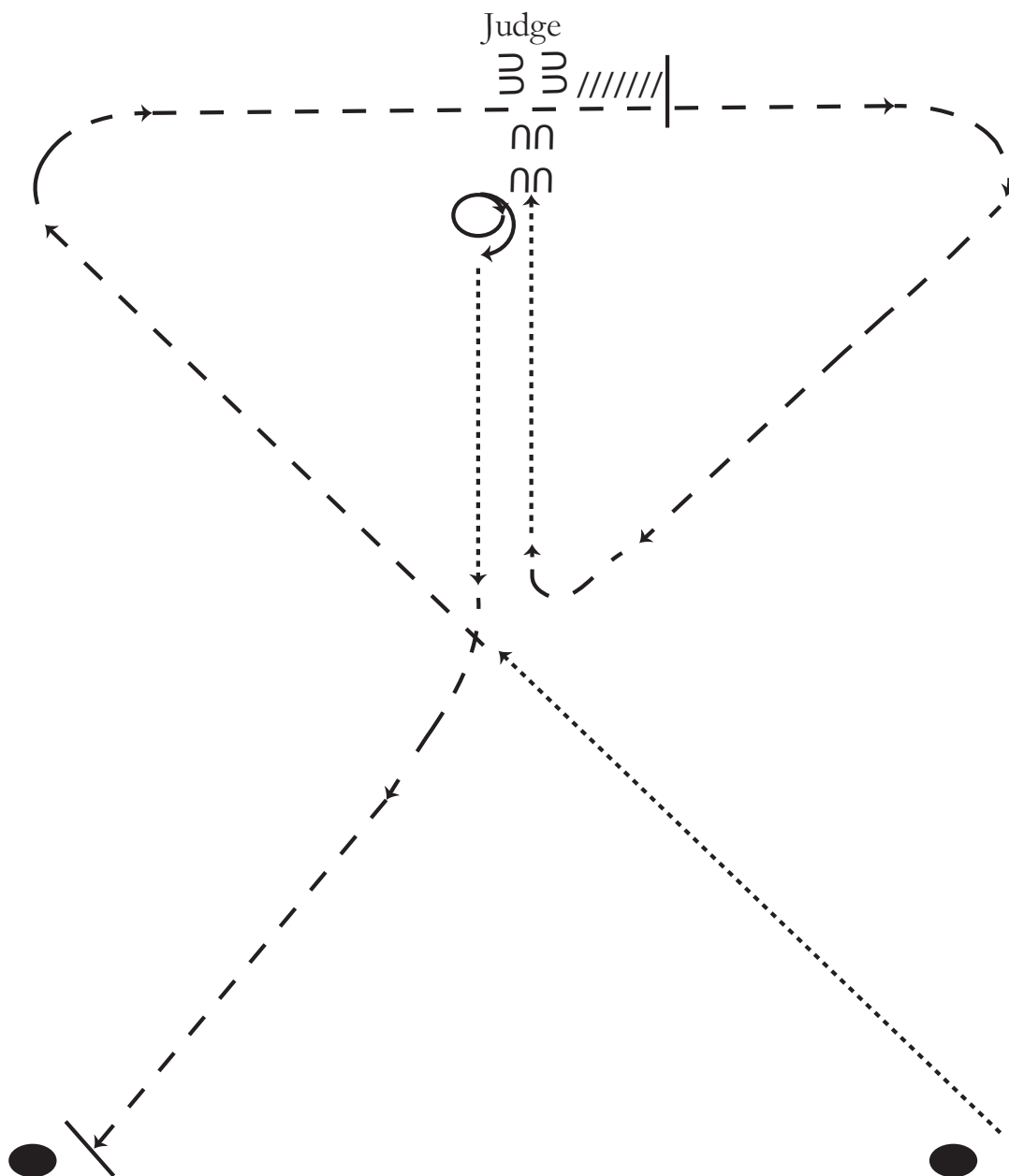

1. Walk across arena. Trot corner and trot past Judge. Stop and back until hindquarters are even with judge
2. Set up for brief inspection
3. Trot across arena and around corner, walk to judge
4. Set-up for full inspection
5. After inspection, 1 1/2 turns and walk. Trot to marker. Stop
6. Exit

NOTE: The drawn description of this pattern is only intended for the general depiction of the pattern. Contestants should utilize the arena space to best exhibit their horses.

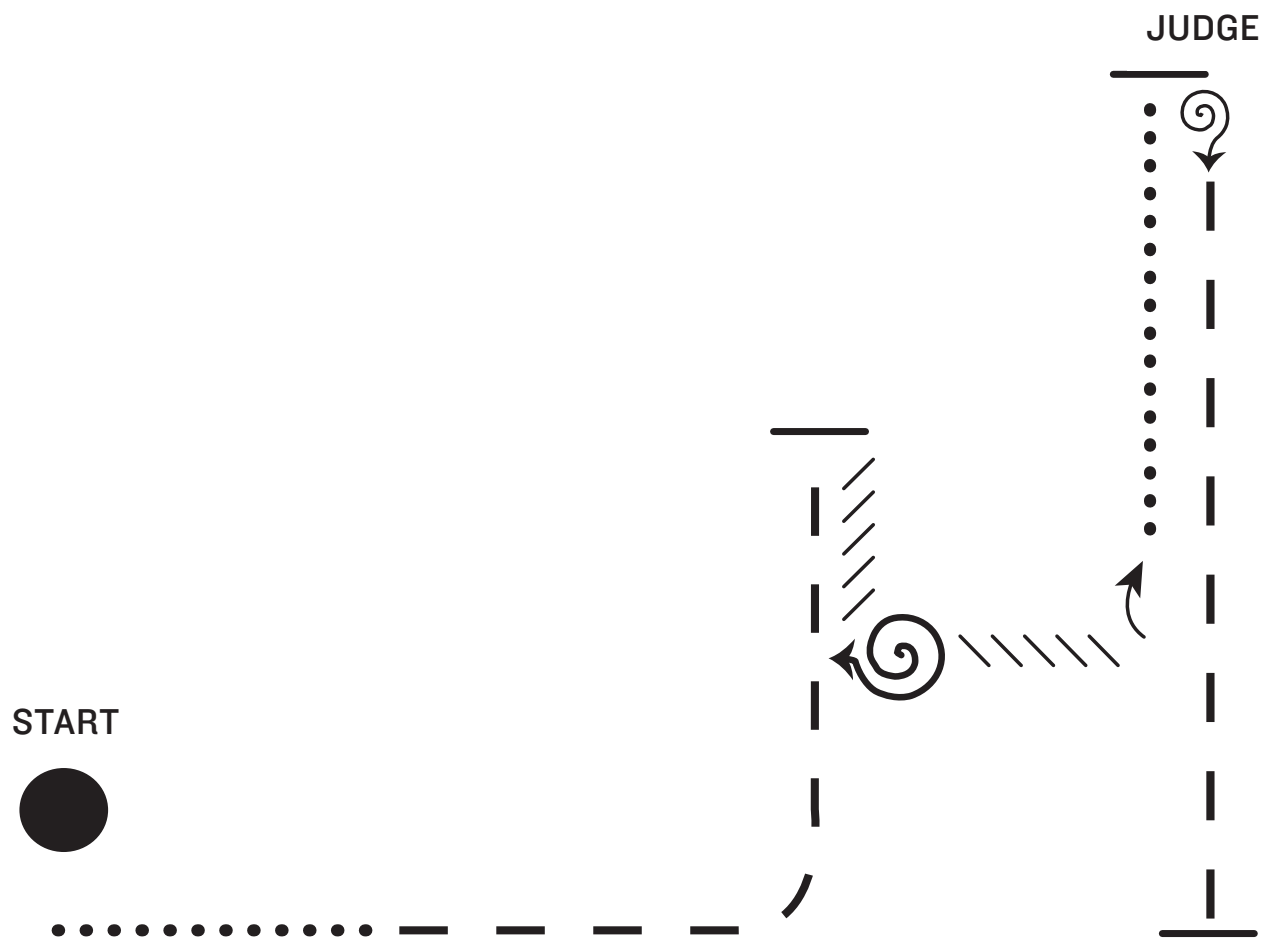

1. Walk
2. Trot corner, stop
3. Set up for brief inspection
4. Back
5. 1 3/4 turn
6. Back, 1/4 turn
7. Walk, stop
8. Set up for inspection
9. After inspection, 1 1/2 turn
10. Trot, stop
11. Exit at a walk or trot

Note: The drawn description of this pattern is only intended for the general depictions of the pattern. Contestants should utilize the arena space to best exhibit their horses.

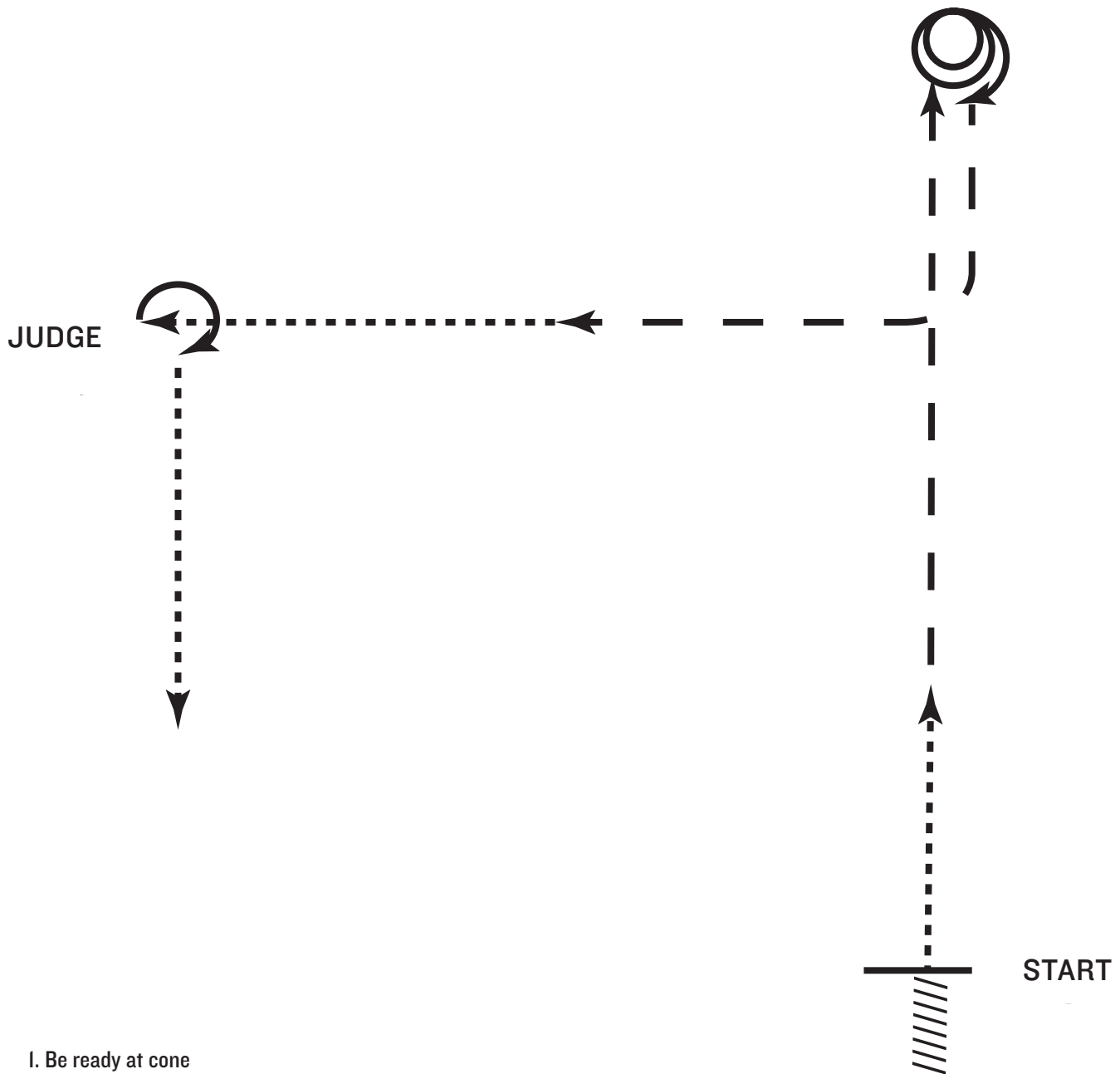

1. Be ready at cone
2. Back 10-12 feet
3. Walk approximately one-third of the distance of your line
4. Trot to the end of your line
5. Stop and execute 2 1/2 turns
6. Trot down line and turn towards the judge
7. After making the corner, trot half way to the judge
8. Walk to the judge
9. Set up for inspection
10. After inspection, execute a 3/4 turn and walk or jog to the exit

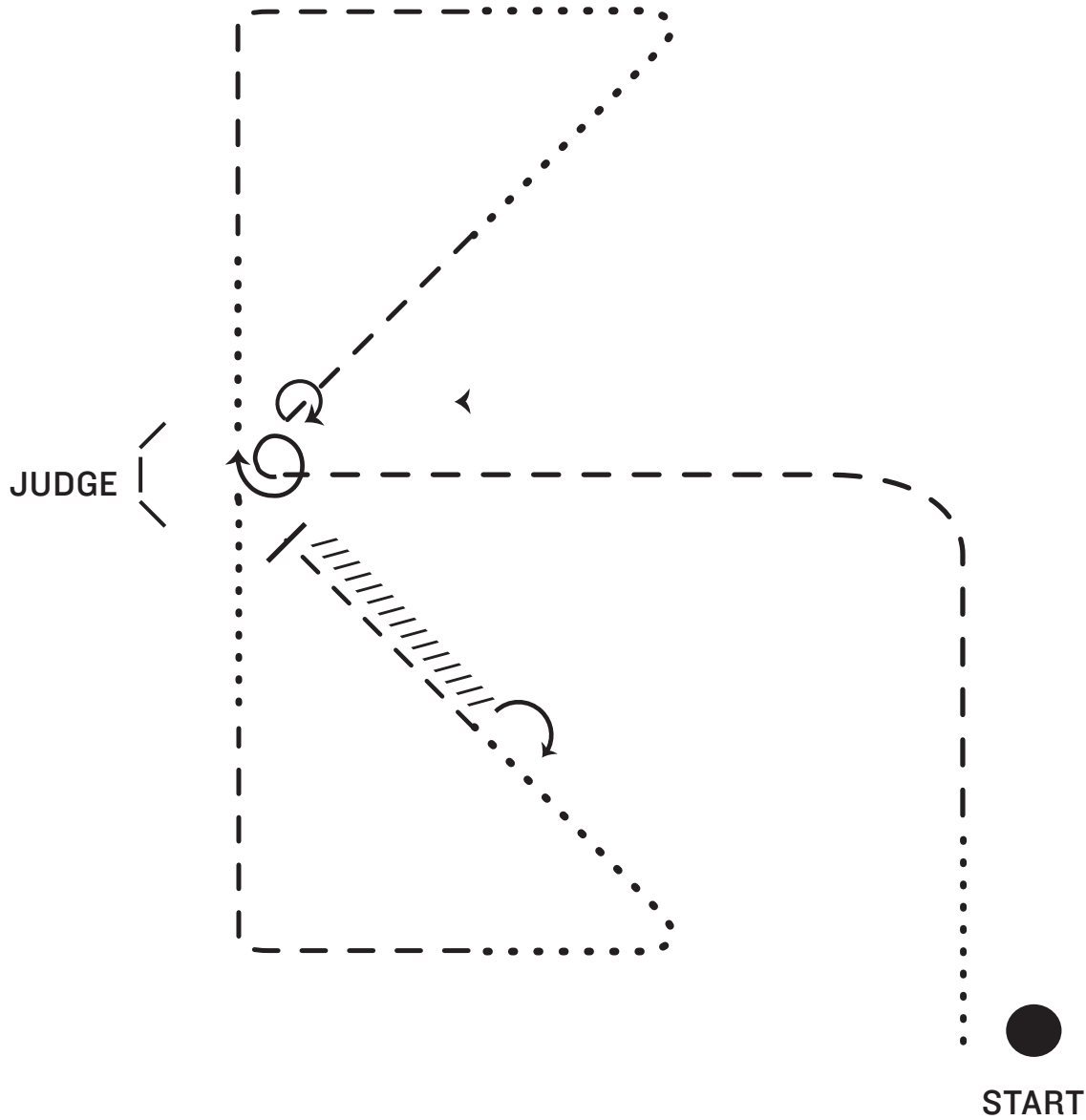

1. Walk, trot corner to judge
2. Halt, no set-up, 1/4 turn
3. Walk, trot, walk, trot triangle
4. Stop, set-up for full inspection
5. 360° turn
6. Walk, trot, walk, trot triangle
7. Stop, set-up (no inspection), back, 3/4 turn
8. Exit at a walk or jog

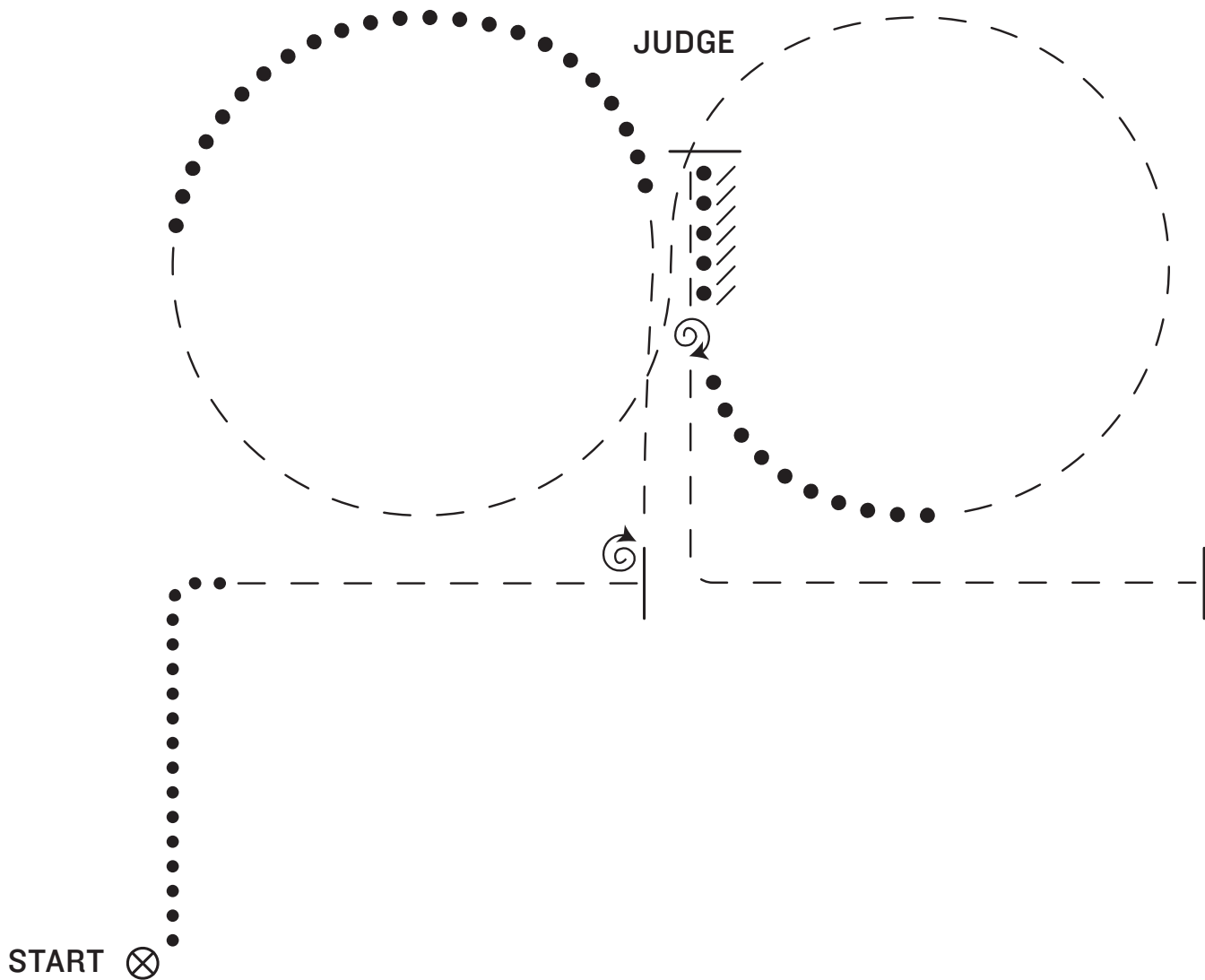

1. Walk corner
2. Trot
3. Set up. Hesitate. Continue
4. 1 3/4 turn
5. Trot toward judge and walk; trot left circle as shown
6. Trot, walk, right circle and walk to judge
7. Set up for full inspection
8. Back 2 horse lengths
9. 1 1/2 turn
10. Trot left corner and stop, no set up
11. Exit at walk or trot